

CORDLESS FRAMING NAILER

DBN900, DBN901

REPAIR MANUAL



1 CONTENTS

1	CONTENTS	2
2	CAUTION	3
3	NECESSARY REPAIRING TOOLS	3
4	LUBRICANT AND ADHESIVE APPLICATION	4
5	TIGHTENING TORQUE SPECIFICATIONS	5
6	REPAIR	6
6-1	Battery, Nails section.....	6
6-1-1	Removing	6
6-2	Magazine section.....	6
6-2-1	Disassembling.....	6
6-2-2	Assembling.....	8
6-3	Electrical parts section.....	12
6-3-1	Disassembling.....	12
6-3-2	Assembling.....	16
6-4	Mechanical section.....	22
6-4-1	Disassembling.....	22
6-4-2	Assembling.....	29
7	CIRCUIT DIAGRAM.....	39
7-1	Section 1.....	39
7-2	Section 2.....	40
8	WIRING DIAGRAM.....	41
8-1	Section 1.....	41
8-2	Section 2.....	42
8-3	Section 3.....	43
8-4	Section 4.....	44
9	TROUBLESHOOTING	45
9-1	Note for Repairing	45
9-2	Test for checking the short-circuit in FET (Field Effect Transistor) of controller	45
10	Flowchart for Troubleshooting	46

2 CAUTION

Repair the machine in accordance with "Instruction manual" or "Safety instructions".

Follow the instructions described below in advance before repairing:

- Wear gloves.
- In order to avoid wrong reassembly, draw or write down where and how the parts are assembled, and what the parts are.
It is also recommended to have boxes ready to keep disassembled parts by group.
- Handle the disassembled parts carefully. Clean and wash them properly.
- Remove Battery, except when it is necessary to check the operation of the machine.

3 NECESSARY REPAIRING TOOLS

Code No.	Description	Use for
1R219	Preset torque wrench 7-23N·m	tightening each bolt
1R269	Bearing puller small	removing Bearing 6002DDW
1R291	Retaining ring pliers S and R	removing/assembling Retaining ring S-13
1R411	Push bar for lead wires	fixing Lead wires
1R479	Shockless hammer (Small)	<ul style="list-style-type: none"> • removing Carrier and Ball bearing 6806DDW • press-fitting Front cushion
1R495	Slotted screwdriver (Small)	<ul style="list-style-type: none"> • removing Pin 4, Urethane ring 3, Compression spring 7, Valve core, Seal ring, Slide ring, X-ring 40, Flat washer 14 and O ring 5 • turning Spur gear 13 • assembling Compression spring 4
1R509	Valve core driver	removing/assembling Valve core
1R511	Air filling adapter	checking and adjusting the air pressure in Chamber

4 LUBRICANT AND ADHESIVE APPLICATION





Description	Amount
 Makita grease FA No.2	a little
 Isoflex NB52	a little
 Lubricant VG32	a little
 Makita grease GA No.2	a little
	Meanwhile, apply much grease to Driver [1] and Holder [2].
 ThreeBond 1342(H) or Loctite 243	Wipe off the adhesive on both new and reused bolts with a carburetor cleaner and apply a small amount of fresh adhesive, because the adhesive may have deteriorated.

Fig. 1



5 TIGHTENING TORQUE SPECIFICATIONS

■ For screws not specified, refer to the general tightening torque in Repair basic manual.

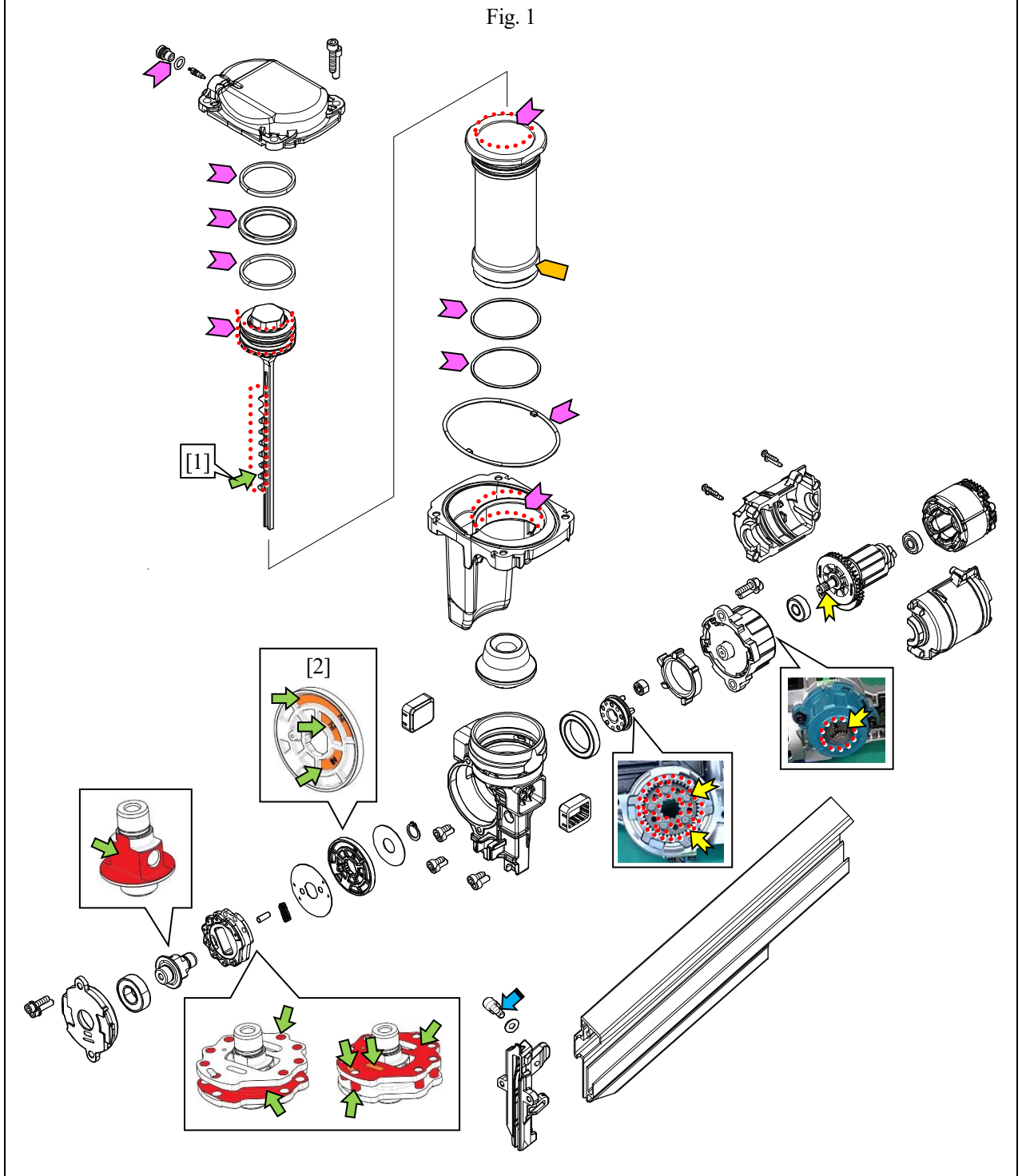
Parts to fasten		Fastener	Tightening torque [N·m]
Nose	↔ Cylinder	H.S.H.bolt M5x12	5 - 15
	↔ Driver guide		5.0 - 9.0
	↔ Lifter cap	H.S.H.bolt M5x20	5.0 - 7.5
	↔ Gear assembly		0.4 - 0.6
	↔ Sensor circuit	Pan head screw M3x8	9.0 - 15.0
Top cap	↔ Chamber	Hex.socket head bolt M6x25	0.29±0.01
	↔ Valve core	Valve core	3.0 - 6.0
Chamber	↔ Valve cap	Valve cap	3.0 - 4.5
Adjuster shaft	↔ Hex lock nut M6-10	Adjuster shaft	1.8 - 3.0
Housing L	↔ Magazine	H S.H.bolt M5x20	0.6 - 1.0
	↔ Switch circuit	Tapping screw bind PT 3x10	5.0 - 9.0
Driver guide	↔ Under driver guide	H S.H.bolt M5x12	9.0 - 13.0
Magazine		Hex.socket head bolt M6x10	

6 REPAIR

6-1 Battery, Nails section

6-1-1 Removing

- 1 Remove Battery and remove the nails from Magazine.

6-2 Magazine section

6-2-1 Disassembling

Fig. 2

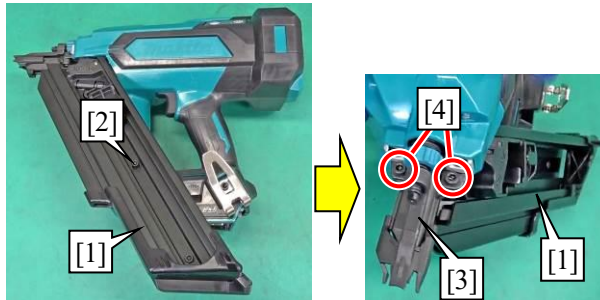

- 1 Remove H.S.H bolts M5x12 [4] (2 pcs) on Driver guide [3] and H.S.H.bolt M5x20 [2] on the center of Magazine section [1], then remove Magazine section [1] from the machine.

Tips

Because H.S.H.bolt M5x20 [2] has a thread locking bolt, if it is difficult to remove with straight type impact driver, remove it with a high torque impact driver.

Fig. 3

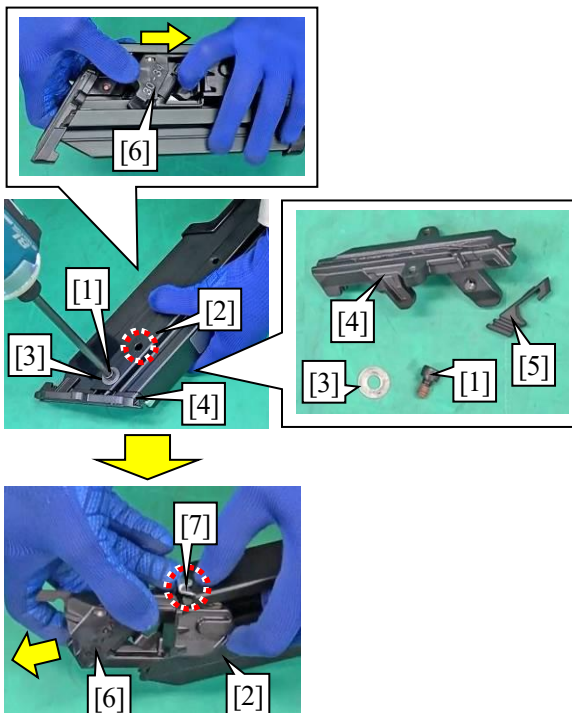

- 2 Remove Hex.socket head bolt M6x10 [1], then remove the following parts from Magazine [2]:
 - Flat washer 7 [3]
 - Under driver guide [4]
 - Pusher cushion [5]

Note

To prevent Pusher lever [6] from popping out due to Spiral spring [7], press Pusher lever [6] with your finger and lower it slightly, then remove Hex.socket head bolt M6x10 [1].

Tips

It is also possible to hold Pusher lever [6] by passing a hex wrench through the hole of Magazine [2].

- 3 Lift up Pusher lever [6] to remove Spiral spring [7] hooked on Magazine [2], then remove Pusher lever [6].

Fig. 4

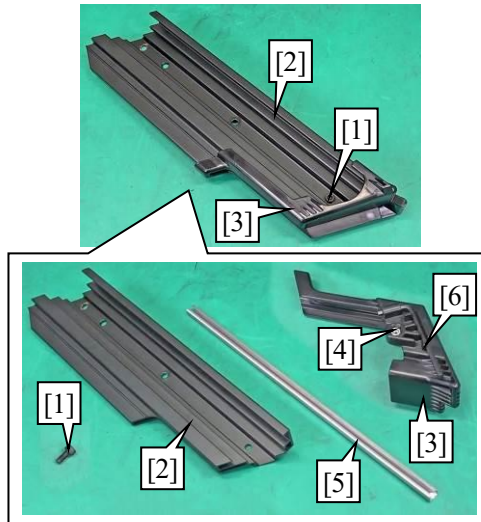

- 4 Remove Hex.socket head bolt M5x12 [1], then remove Magazine cap [3] (with Hex.lock nut M5-8 [4]) from Magazine [2].
- 5 Pull out Nail rail [5] from Magazine [2].

Note

If Hex.wrench 4 [6] is attached when you received the machine from the user, hold it so that it does not fall off.

Fig. 5

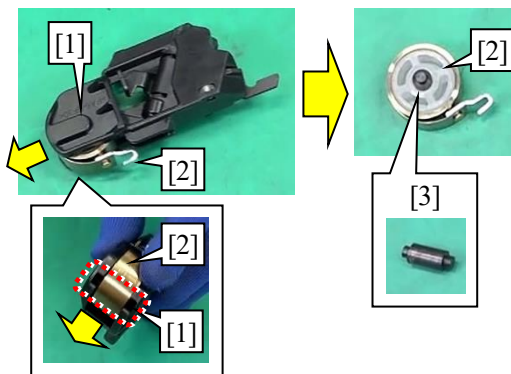

- 6 Remove Spiral spring [2] from Pusher lever [1], then remove Pin 5-8 [3].

Tips

Pin 5-8 [3] is inserted in the notch of Pusher lever [1], therefore, pull and remove Spiral spring [2] straight.

Fig. 6

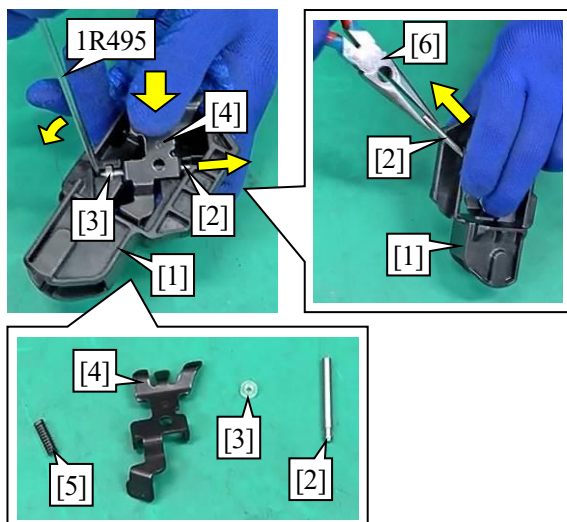

- 7 Remove the following parts from Pusher lever [1]:

- Pin 4 [2]
- Urethane ring 3 [3]
- Pusher [4]
- Compression spring 3 [5]

Tips

- While holding Pusher [4], push out Pin 4 [2] sideways with 1R495, then remove Urethane ring 3 [3], and then pull out Pin 4 [2] with long-nose pliers [6].
- Remove Urethane ring 3 [3] in Pusher lever [1] by lifting it up.

Fig. 7

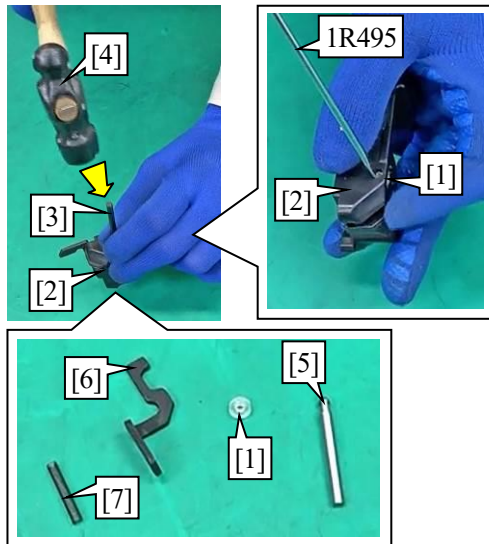

8 Face the assembled side of Urethane ring 3 [1] upward and hold Pusher lever [2] so that it does not tilt, then push out Pin 4 [5] with an appropriate Round bar jig [3] and a metal hammer [4] to remove the following parts.

- Lock plate [6]
- Compression spring 3 [7]
- Urethane ring 3 [1]

Tips

- Remove Compression spring 3 [7] by tilting Pusher lever [2].
- Remove Urethane ring 3 [1] by tilting Pusher lever [2] or pushing it out with 1R495.

6-2-2 Assembling

Fig. 8

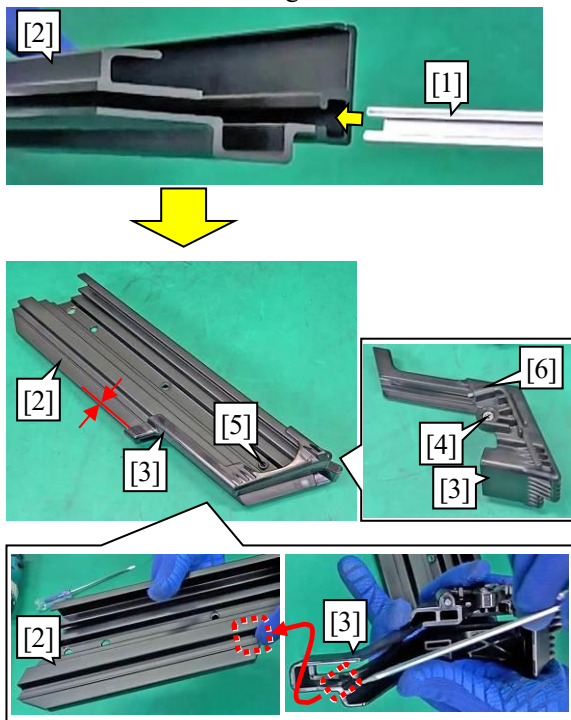

- 1 Face the flat end (non-protruding side) of Nail rail [1] toward the rear side of the machine, then align C-shape of Magazine [2] with C-shape of Nail rail [1], and then insert Nail rail [1].
- 2 Assemble Magazine cap [3] (with Hex.lock nut M5-8 [4]) to Magazine [2] so that its protrusion fits into the guideway of Magazine [2], then tighten Hex.socket head bolt M5x12 [5].

Note

- If there was a Hex.wrench 4 [6] when you received the machine from the user, check that Hex.wrench 4 [6] is attached.
- While pressing Magazine cap [3] against Magazine [2], assemble it so that there are no gap at the lower portion between Magazine [2] and Magazine cap [3].

Fig. 9

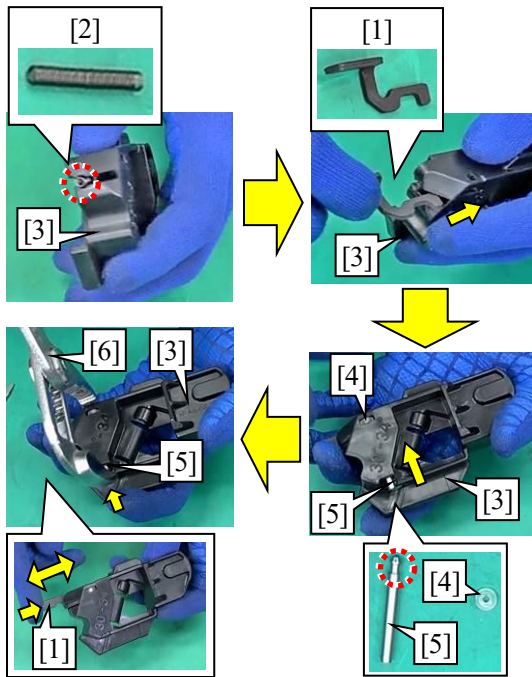

- 3 Insert Compression spring 3 [2] into the round hole in Pusher lever [3] at the assembling position for Lock plate [1], then insert the bent side of Lock plate [1] into the assembling position.
- 4 Assemble Urethane ring 3 [4] into the slit of Pusher lever [3], then insert Pin 4 [5] from the side with the step into the hole on the opposite side.
- 5 While holding Lock plate [1] slightly, assemble Pin 4 [5] with Water pump pliers [6].

Note

Check that Lock plate [1] moves back and forth properly.

Fig. 10

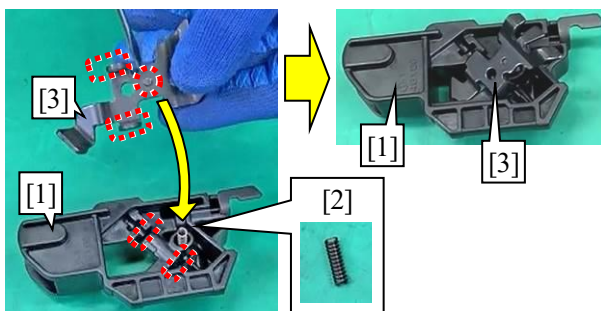

- 6 Assemble Compression spring 3 [2] into the hole of Pusher lever [1].
- 7 Align the following portions, then assemble them.
 - Protrusion of Pusher [3] and Compression spring 3 [2]
 - Holes in Pusher lever [1] for passing Pin 4 and holes of Pusher [3].

Fig. 11

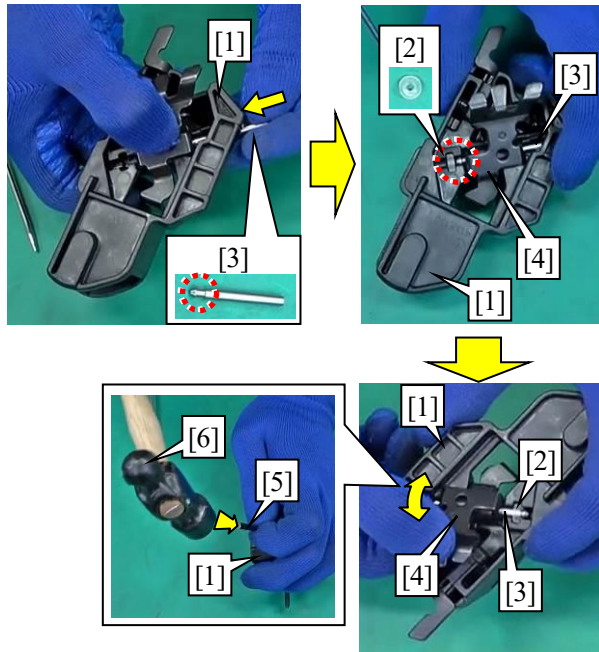

8 Insert Pin 4 [3] from its stepped side into the hole of Pusher lever [1] on the opposite side of the space for assembling Urethane ring 3 [2], and while aligning the positions, push Pin 4 [3] until the stepped side protrudes from the space for Urethane ring 3 [2].

9 Assemble Urethane ring 3 [2] into Pusher lever [1].

Note

As the step of Pin 4 [3] where Urethane ring 3 [2] is inserted may interfere with Pusher [4], Pin 4 [3] may be inserted incompletely. Therefore, check that the step of Pin 4 [3] protrudes from Pusher [4].

10 Push in Pin 4 [3] with an appropriate Round bar jig [5] and a metal hammer [6].

Note

- Check that Urethane ring 3 [2] is assembled in the step of Pin 4 [3].
- Check that Pusher [4] moves up and down properly.

Fig. 12

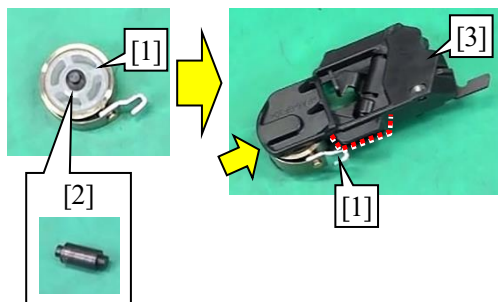

11 Assemble Pin 5-8 [2] to Spiral spring [1], then assemble Spiral spring [1] to Pusher lever [3].

Tips

Because the hook portion of Spiral spring [1] should be hooked and assembled to the end face of Magazine, assemble Spiral spring [1] so that its hook comes to the side with the short rib of Pusher lever [3].

Fig. 13

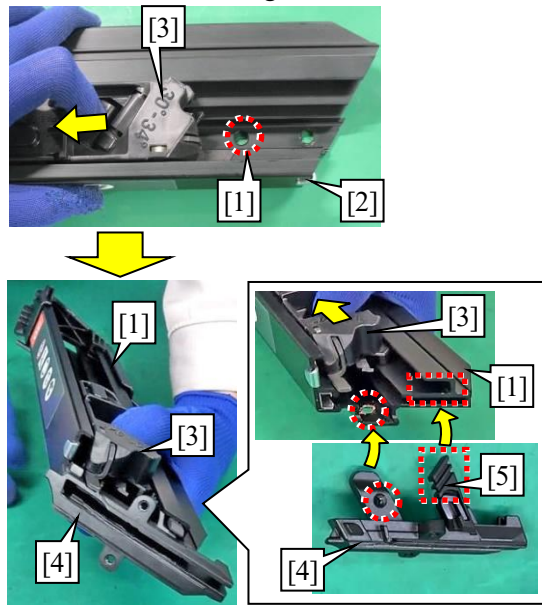

- 12** Hook the hook portion of Spiral spring [2] to the end face of Magazine [1], then assemble Pusher lever [3].
- 13** Assemble the hook of Pusher cushion [5] to the notch of Under driver guide [4], then assemble Under driver guide [4] to Magazine [1].

Tips

- While pressing and holding Pusher lever [3] along the shape of Magazine [1], assemble Pusher cushion [5] to the groove of Magazine [1] and assemble so that the protrusion of Under driver guide [4] enters into the concave where the screw hole of Magazine [1] is located.
- Pusher lever [3] can be held by passing a hex wrench through the hole of Magazine [1]. At that time, do not pass the hex wrench through the screw hole on the top side of Magazine [1].

Fig. 14

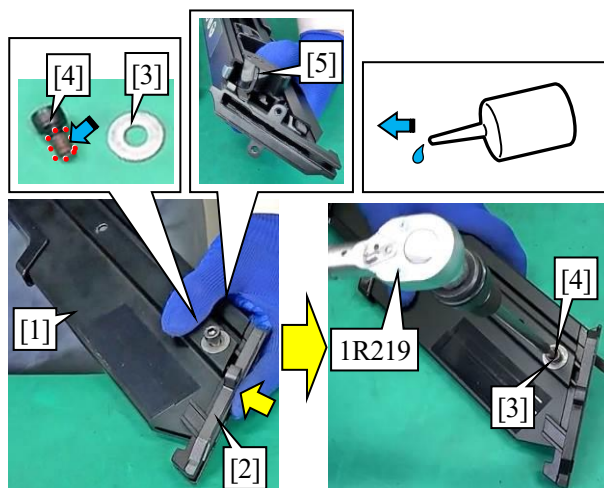

- 14** While pressing Under driver guide [2] against Magazine [1], assemble Flat washer [3], then tighten Hex.socket head bolt M6x10 [4].

Tips

It is easier to work by pushing and holding Pusher lever [5] against the end of a workbench.

Note

If there is a gap between Magazine [1] and Under driver guide [2], a nail feed failure may occur. Therefore, when tightening Hex.socket head bolt M6x10 [4], be sure to hold Under driver guide [2].

- 15** Fully tighten Hex.socket head bolt M6x10 [4] to the specified torque with 1R219.

Note

Apply the specified adhesive to Hex.socket head bolt M6x10 [4].

Fig. 15

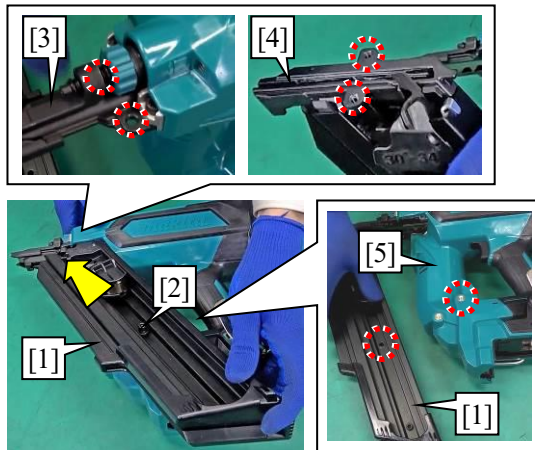

- 16** Align the main body and Magazine section [1], and temporarily tighten H.S.H.bolt M5x20 [2] to hold Magazine section [1] to the main body.

Tips

- Align the screw hole of Driver guide [3] with the screw hole of Under driver guide [4] by inserting Magazine section [1] obliquely to the main body.
- Align the position of the upper threaded hole of Housing L [5] of DBN900 / the lower threaded hole of Housing L of DBN901 with the center hole of Magazine section [1].

Note

Housing L has two threaded holes, but depending on models, either one is not used.

Fig. 16

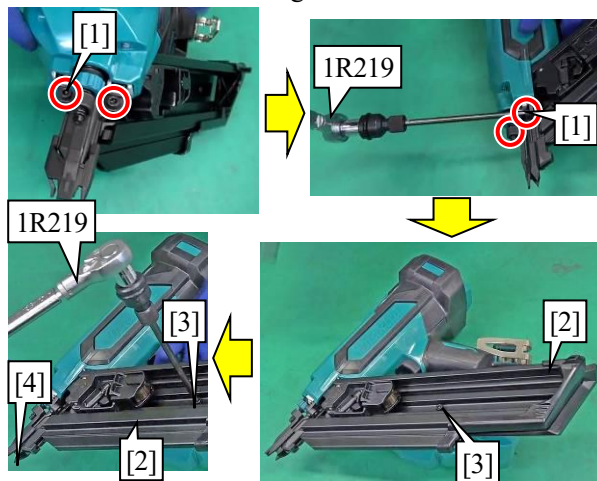

- 17** Tighten H.S.H.bolts M5x12 [1] (2 pcs) firmly to the specified torque with 1R219.

- 18** Tighten H.S.H.bolt M5x20 [3] of Magazine section [2] to the specified torque with 1R219.

Tips

Driver [4] slightly protrudes from Contact top, but when the machine is turned on and operated, Driver [4] is wound up to the normal standby position.

Note

Housing L has two screw holes, but either one is not used.

6-3 Electrical parts section

6-3-1 Disassembling

Fig. 17

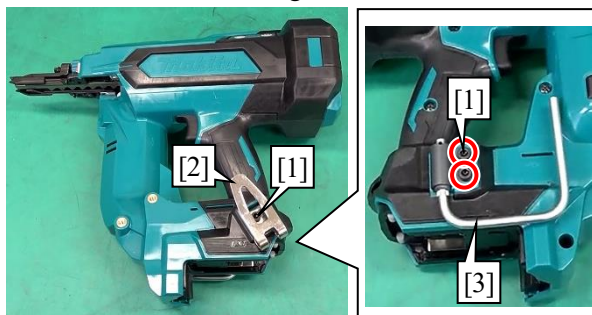

■ If Hook / Sky hook has been attached.

- 1** Remove H.S.H.bolt M5x12 [1], then remove Hook [2] from the machine.
- 2** Remove H.S.H.bolts M5x12 [1] (2 pcs), then remove Sky hook [3].

Note

Replace Hook [2] / Sky hook [3] if necessary.

Fig. 18

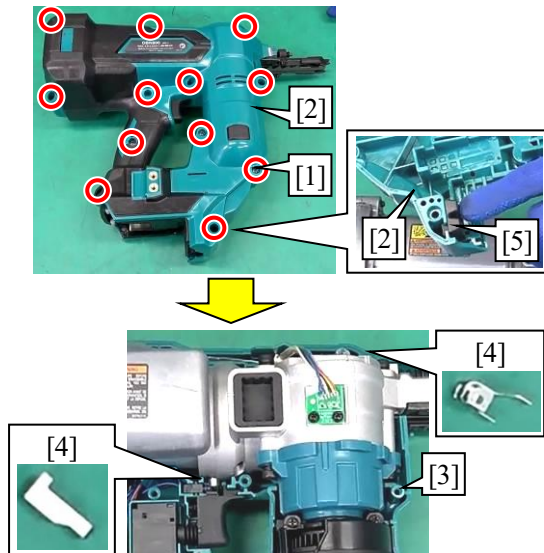

- 3 Remove Tapping screws 4x18 [1] (12 pcs), then remove Housing R [2].
- 4 Remove Leaf springs [4] (2 pcs) from Housing L [3].

Note

- Be careful not to bend Leaf springs [4] (2 pcs).
- Replace Battery cushion [5] on Housing R [2] if necessary.

Fig. 19

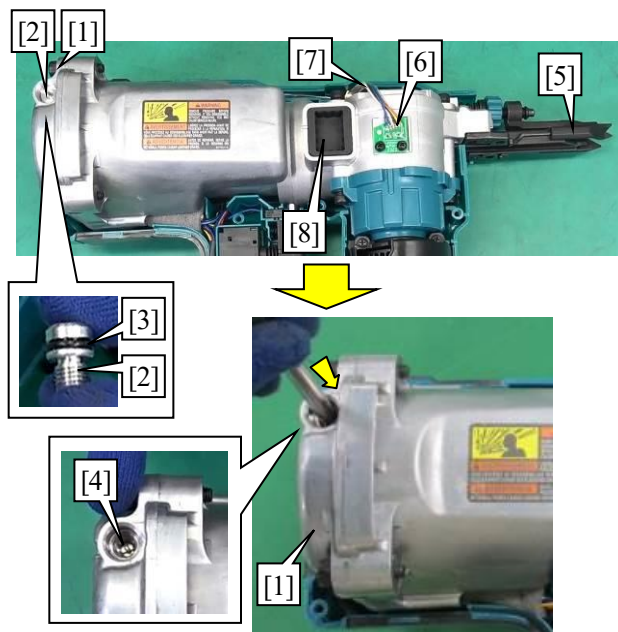

- When repairing the mechanical section.
- 5 Remove Valve cap [2] (with O ring 8 [3]) from Top cap [1].
 - 6 Press the protrusion on the top of Valve core [4] with a flat-tipped round bar or hex bit, and release compressed air firmly until the sound of escaping air stops.

Note

Be sure to release compressed air in advance when disassembling the machine section other than Contact top [5], Sensor circuit [6], Lead wires [7] and Side cushion [8] because the work without release compressed air causes a malfunction and parts are blown off by air pressure.

Fig. 20

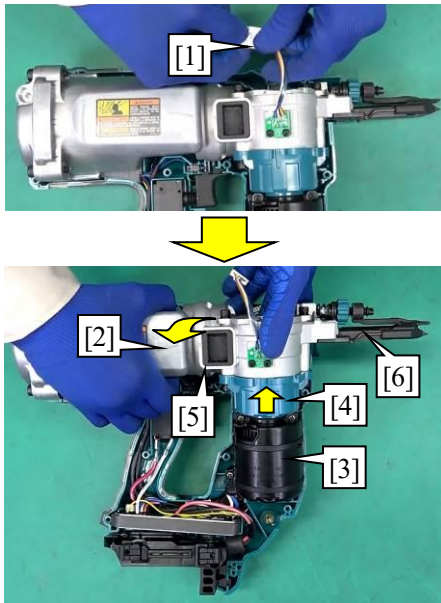

- 7 Disconnect the connector [1] of Sensor circuit.
- 8 Lift up Cylinder section [2], then pull out Gear section [4] from Motor section [3] to remove Mechanical section [5].

Note

When removing Mechanical section [5], be careful not to touch Driver guide [6] and lift up Cylinder section [2]. Because a large amount of grease is applied to Driver guide [6] and air is filled, Driver may come out mechanically.

Fig. 21

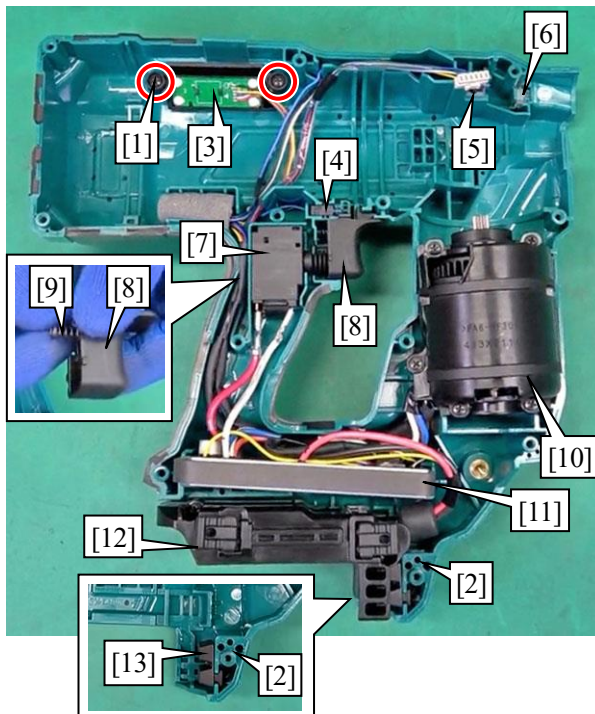

- 9 Remove Tapping screws bind PT 3x10 [1] (2 pcs), then remove the following parts from Housing L [2]:

- Switch circuit [3]
- Switch unit [4] (without Switch cover)
- Switch unit [5] (with Switch cover)
- LED circuit [6]
- Switch [7]
- Trigger [8]
- Compression spring 4 [9]
- Motor section [10]
- Controller [11]
- Battery holder section [12]

Note

Replace Battery cushion [13] on Housing L [2] if necessary.

Fig. 22

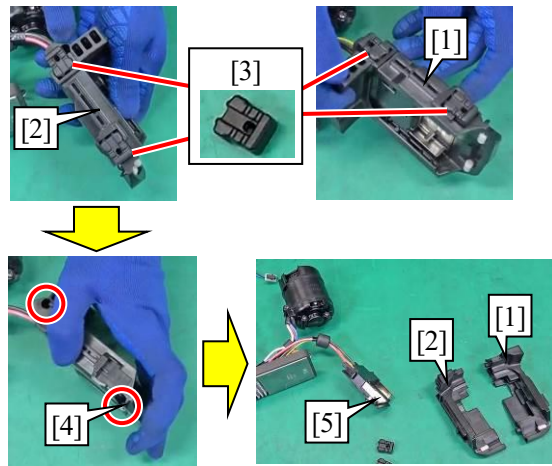

- 10 Remove Holder cushions [3] (4 pcs) from Battery holder L [1] and Battery holder R [2].
- 11 Remove Tapping screws bind PT 3x16 [4] (2 pcs), then remove Battery holder L [1] and Battery holder R [2] from Terminal [5].

Note

Check that four pcs of Holder cushion [3] are removed. Due to deformation, they are left in either Battery holder L [1] and Battery holder R [2] or Housing L and Housing R.

Fig. 23

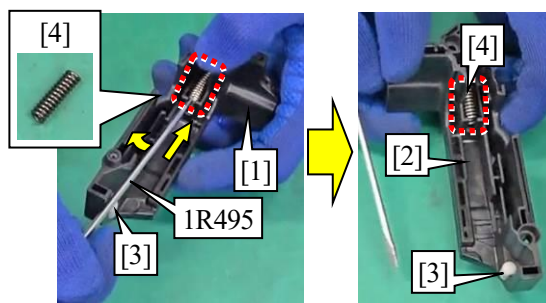

- 12 Remove Compression springs 7 [4] (2 pcs) from Battery holder L [1] and Battery holder R [2] (with Rubber pins 6 [3] (1 pc each)) with 1R495.

Fig. 24

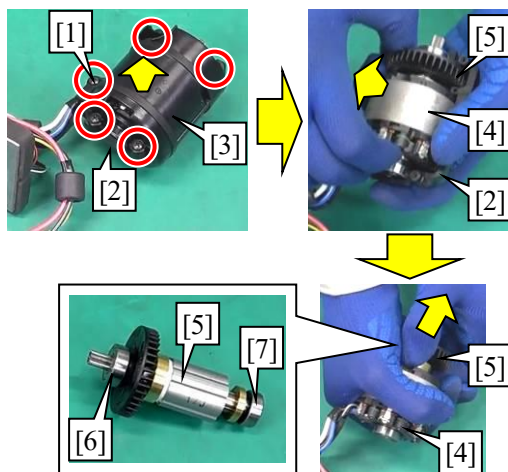

- 13 Remove Tapping screws bind PT 3x16 [1] (5 pcs), then lift up and remove Motor housing R [3] from Motor housing L [2].
- 14 Remove the unit of Stator [4] and Rotor [5] from Motor housing L [2], then pull out Rotor [5] from Stator [4].

Note

Replace Ball bearing 608ZZ [6] and Ball bearing 607LLB [7] on both ends of Rotor [5] if necessary.

Fig. 25

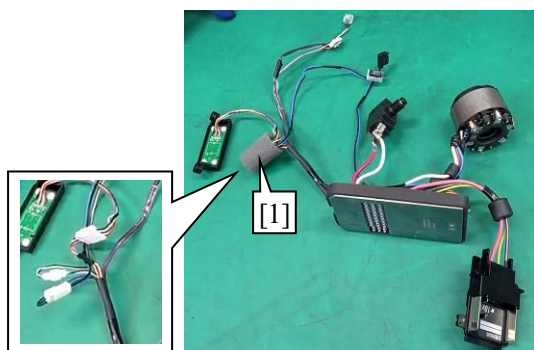

- 15 Remove Sponge [1], then disconnect Connectors and Receptacles.

6-3-2 Assembling

- 1 Assemble the electrical parts in accordance with Circuit diagram and Wiring diagram.

Fig. 26

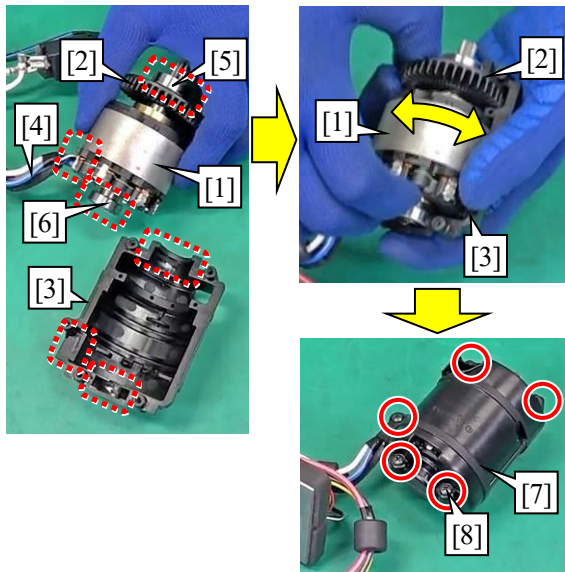

- 2 Assemble Rotor [2] to Stator [1], then assemble the unit to Motor housing L [3].

Tips

Set Ball bearing 608ZZ [5] and Ball bearing 607LLB [6] of Rotor [2] in place so that the lead wires [4] of Stator [1] come out from the notch of Motor housing L [3].

Note

Stator [1] has stoppers not to rotate in Motor housing. Try turning it by hand and check it does not rotate.

- 3 Assemble Motor housing R [7] with Tapping screws PT 3x16 [8] (5 pcs).

Fig. 27

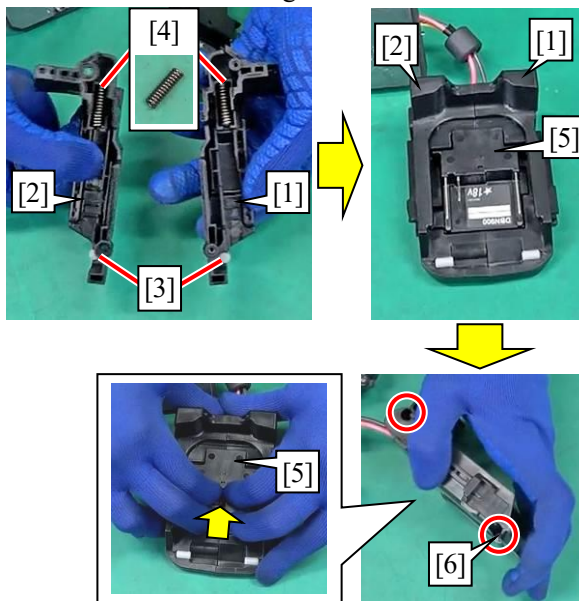

- 4 Assemble Compression springs 7 [4] (2 pcs) in the square concaves of Battery holder L [1] and Battery holder R [2] (with Rubber pins 6 [3] (1 pc each).

- 5 Assemble Battery holder L [1] and Battery holder R [2] along the shape of Terminal [5], then tighten Tapping screws bind PT 3x16 [6] (2 pcs).

Note

- Check that Compression springs 7 [4] (2 pcs) are assembled straight.
- Check that Terminal [5] moves backward by pushing it.

Fig. 28

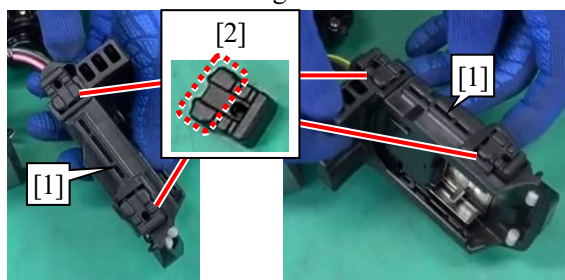

- 6 Assemble Holder cushions [2] (4 pcs) to Battery holder section [1].

Note

Align the wider side of Holder cushion [2] with the U-shape of Battery holder section [1].

Fig. 29

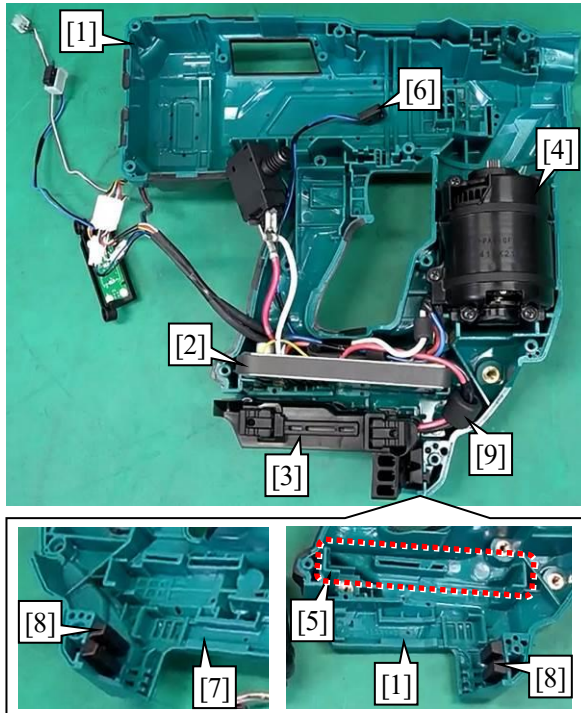

- 7 Assemble the following parts to Housing L [1]:
- Controller [2]
 - Battery holder section [3]
 - Motor section [4]

Tips

Assemble Controller [2] along the U-shape [5] of Housing L [1], then put Switch unit [6] lead wires so that they come to the lowest position.

Note

- Check that Battery cushions [8] (2 pcs) are assembled to Housing L [1] and Housing R [7].
- If Line filter [9] is equipped, assemble Battery holder section [3] so that Line filter [9] is placed in the front side of Controller [2].

Fig. 30

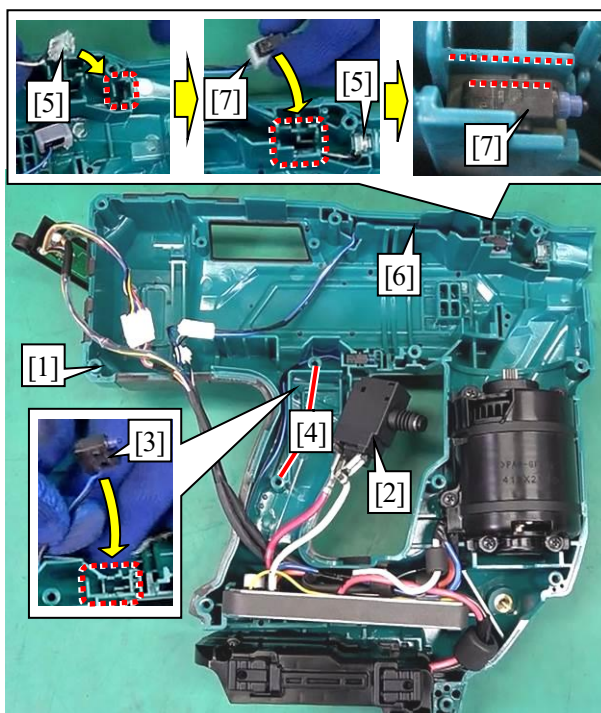

- 8 Assemble Switch unit (without Switch cover) [3] to the two notches of Housing L [1] which Switch [2] is assembled, then route Lead wires through the gap between the upper side and the side of Screw boss [4], and then fix them with 1R411.
- 9 Face LED circuit lead wires [5] toward Motor [1] to assemble LED circuit [5] to the top side of the machine, then route Lead wires and fix them in the slit [6] with 1R411.
- 10 Assemble Switch unit (with Switch cover) [7] into the notch in front of LED circuit [5], then fix Lead wires in the slit [6] with 1R411.

Tips

Fix Switch units [3] [7] so that their lead wires face toward Motor [1].

Note

When assembling Switch units [3][7], assemble them firmly to the bottom so that they do not cause an operation failure. Especially, Switch unit (with Switch cover) [7] is easy to tilt due to the elastic force of Switch cover, so assemble Switch unit (with Switch cover) [7] firmly so that the upper surface of Switch unit (with Switch cover) [7] and the rib are parallel to each other.

Fig. 31

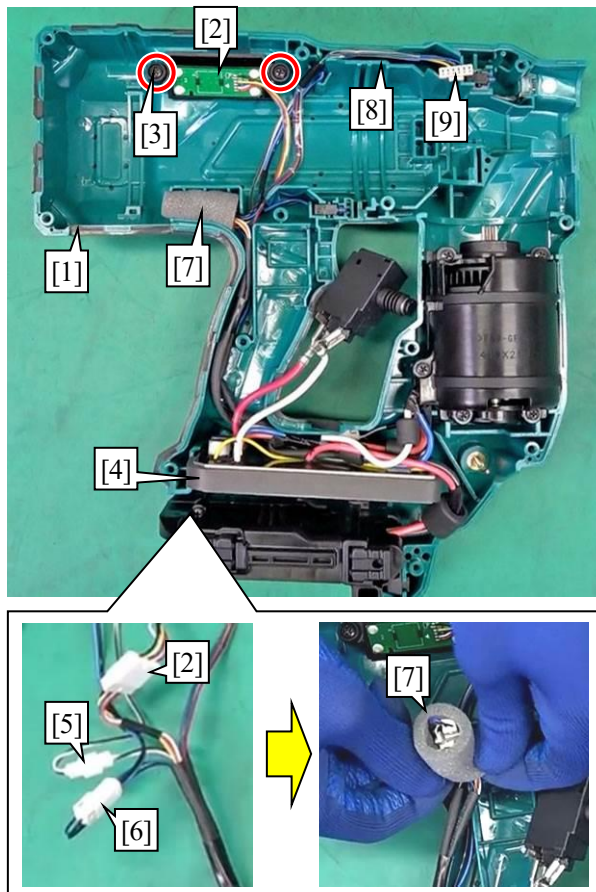

- 11** Assemble Switch circuit [2] to Housing L [1], then tighten Tapping screws bind PT 3x10 [3] (2 pcs).

Note

When assembling Switch circuit [2], be careful the assembling orientation of the upper and lower.

- 12** Put the lead wires of Switch circuit [2] and Controller [4] in Housing L [1], then bundle the three connectors of Switch circuit [2], Switch unit [5] and LED circuit [6] with Sponge [7].

Tips

- Bundle the three connectors of Switch circuit [2], Switch unit [5] and LED circuit [6] with Sponge [7], then place them in the bracket of Housing L [1].
- Route Lead wires bundled in Sponge [7] so that they do not put on Rib, then fix them with 1R411.

- 13** Place the remaining lead wires of Connector [9] in the slit [8] on the upper side of Housing L [1].

Fig. 32

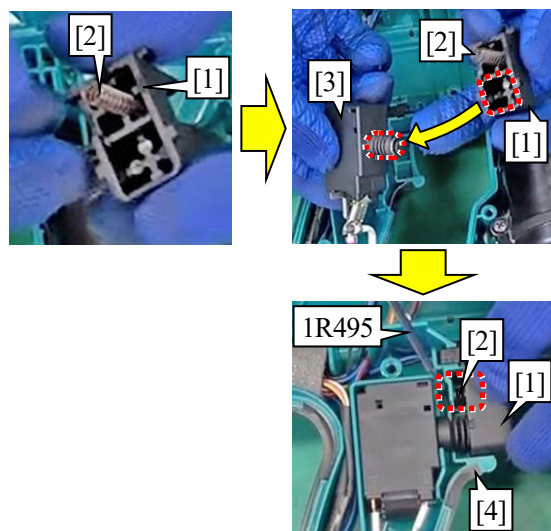

- 14** Assemble Compression spring 4 [2] into the hole with the cross-shaped rib of Trigger [1], then fix the protrusion of Switch [3] in the other hole of Trigger [1].

- 15** Assemble Switch [3] and Trigger [1] to Housing L [4] along its shape of notch.

Note

To prevent Compression spring 4 [2] from putting on the rib, compress Compression spring 4 [2] with 1R495 so that it touches the rib from the side.

Fig. 33

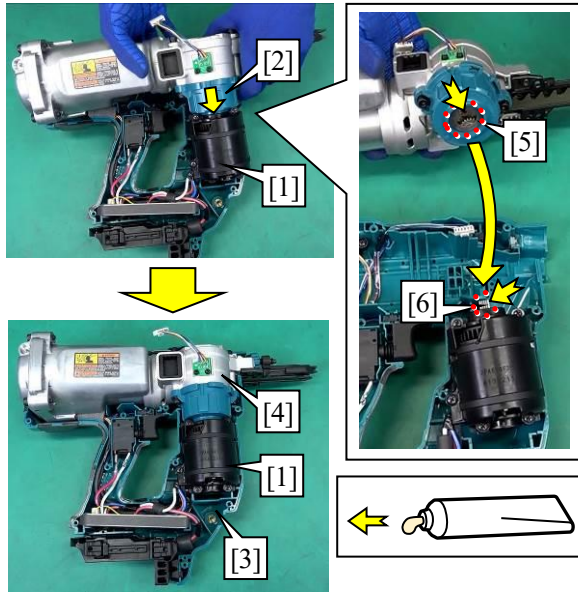

- 16 Assemble Gear section [2] to Motor section [1], then assemble the mechanical section [4] to Housing L [3].

Note

Apply a small amount of the specified grease onto the top of Rotor [6] or the center of Gear assembly [5].

Fig. 34

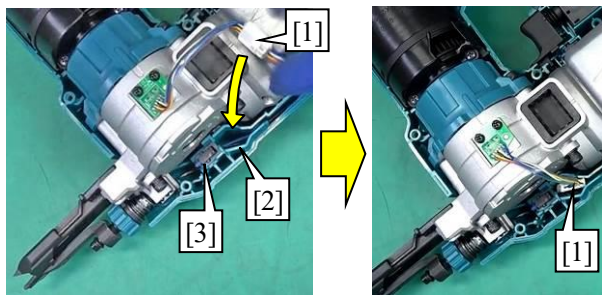

- 17 Connect the connector of Sensor circuit [1], then place it in the space on the rear side of Switch unit [3] on the top side of Housing L [2].

Note

Fix Lead wires in place with 1R411 so that they do not come off.

Fig. 35

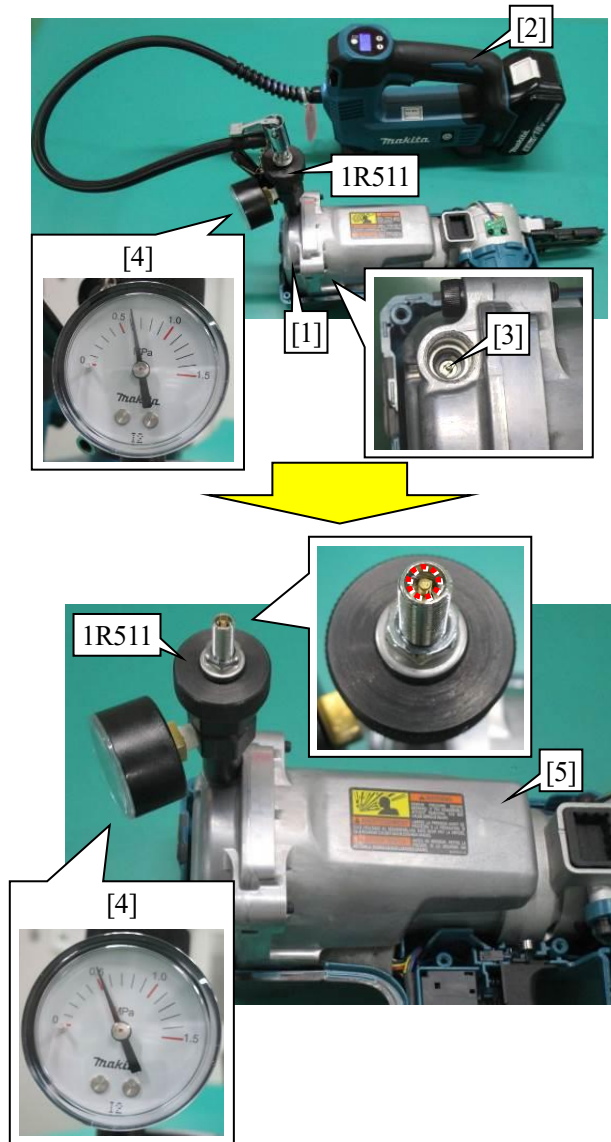

■ When repaired the mechanical section.

- 18 Attach 1R511 to Top cap [1], then inflate to Chamber with slightly higher air pressure than the specified value (0.51MPa) with Cordless air inflator [2] (DMP180/001G etc.)

Tips

Commercial manual air inflators can be substituted for Cordless air inflator [2].

Note

- Compressed air will be released if Valve core [3] is loosened, so check that Valve core [3] is tightened with 1R509 before repairing.
- Tighten Valve core [3] lightly after seated on because too much tightening causes threads to be broken.

- 19 Leave the machine for about one minute, then press the pin on the top of 1R511 while checking the pressure gauge [4] to release the air until the specified air pressure (0.51 MPa) is reached.

- 20 Remove 1R511 from Top cap [1].

Tips

- Immediately after inflating Chamber [5], its inner temperature rises and the air pressure temporarily increases. So, it is necessary to wait for a minute to bring the temperature to the same level as room temperature.
- Compressed air is released slightly when removing 1R511. At this time, the air pressure in Chamber [5] does not change because the released air was accumulated air in 1R511.

Note

Because the air pressure in Chamber [5] varies depending on the temperature, repair the machine in a room between 15°C and 25°C to maintain the specified air pressure.

Fig. 36

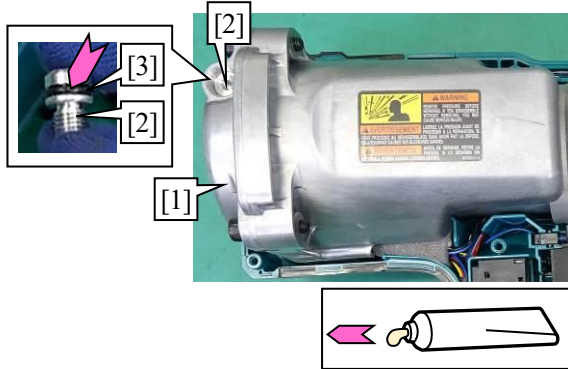

■ When repairing the mechanical section.

- 21 Remove 1R511, then tighten Valve cap [2] (with O ring 8 [3]) to Top cap [1].

Tips

When tightening Valve cap [2], sometimes the threads of Valve cap [2] do not engage with the threaded hole of Top cap [1] because O ring 8 [3] rise, so push it slightly to insert O ring 8 [3] fully, then tighten Valve cap [2].

Note

- Apply a small amount of the specified grease to O ring 8 [3].
- Because the tightening torque of Valve cap [2] is specified low, if using DF012D, set the adjusting ring to “1” position. If tightened manually, after it is seated on Top cap [1], tighten it just a little.

Fig. 37

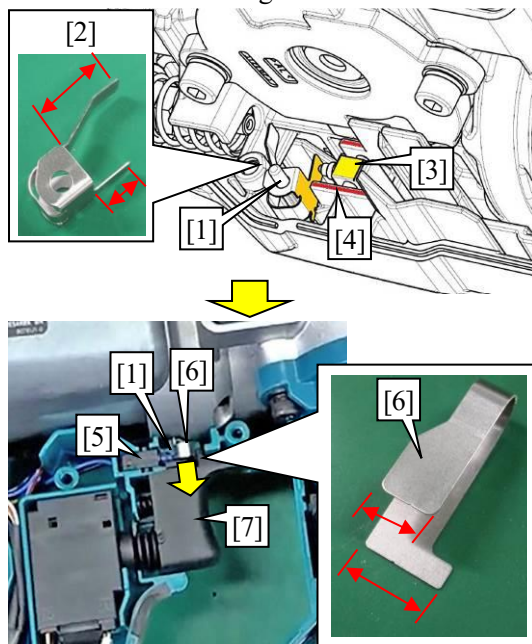

- 22 Assemble Leaf spring [2] to the pin positioned to upper side of Housing L [1] so that the longer pin side of Leaf spring [2] faces toward the front side of machine and the shorter pin side faces toward the rear side of machine.

Note

- Check that the upper surface (yellow marked portion) of Switch unit [3] is below the upper surface of Rib [4] (red marked portions).
- Assemble Leaf spring [2] so that the contact surface to Switch faces toward the front of Switch unit [3].

- 23 Assemble the wide side on the bottom of Leaf spring [6] to the slit of Housing L [1] directly next to the other Switch unit [5] / the narrow side on the bottom facing toward the front side of the machine.

Note

When assembling Housing R, tilt Leaf spring [6] slightly toward Trigger [7] to prevent it from bending.

Fig. 38

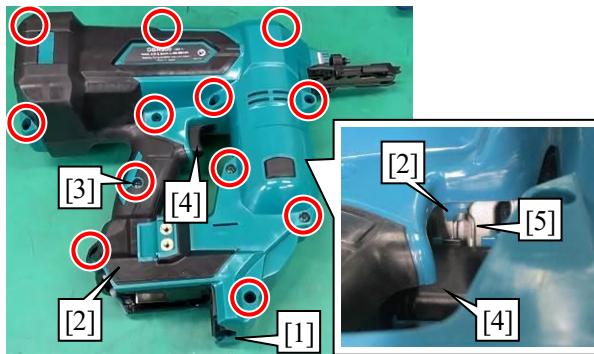

- 24** Assemble Housing R [2] to Housing L [1], then tighten Tapping screws 4x18 [3] (12 pcs).

Note

- Assemble Housing R [2] straight. Be careful not to bend Leaf springs (2 pcs). Especially for Leaf spring [5] near Trigger [4], visually check that the rib end of Housing R [2] is inserted into the bottom side of Leaf spring [5].
- Check that Trigger [4] can be pulled properly.

Fig. 39



- If Hook or Sky hook has been attached.

- 25** Assemble Sky hook [2] to Housing section [1] with H.S.H.bolts M5x12 [3] (2 pcs).
- 26** Assemble Hook [4] to Housing section [1] with H.S.H.bolt M5x12 [3].

6-4 Mechanical section

6-4-1 Disassembling

- 1** Release the compressed air in Chamber. (Fig. 19)

Note

Be sure to release the compressed air in advance when disassembling the machine section other than Contact top, Sensor circuit, Lead wires and Side cushion because the repair without releasing the compressed air causes a malfunction and the parts are blown off by air pressure.

Fig. 40

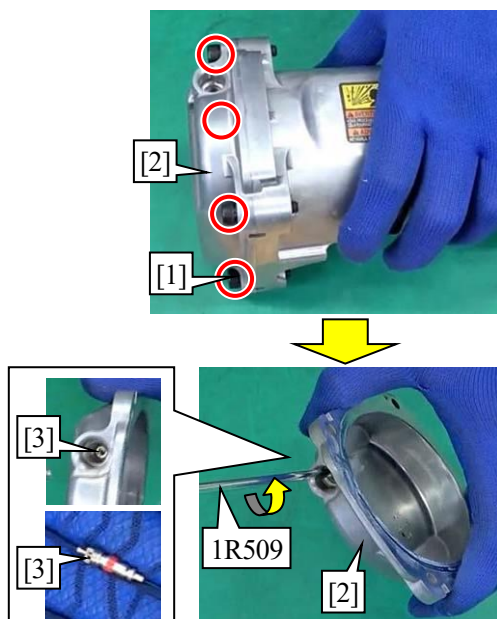

- 2** Remove Hex.socket head bolts M6x25 [1] (4 pcs), then remove Top cap [2].
- 3** Remove Valve core [3] from Top cap [2] by turning it counterclockwise with 1R509.

Tips

If Valve core [3] is loose and cannot be removed, shake Top cap [2] or push Valve core [3] from the rear side with 1R495 because it is difficult to fall off due to the sealing and the tapering design.

Fig. 41

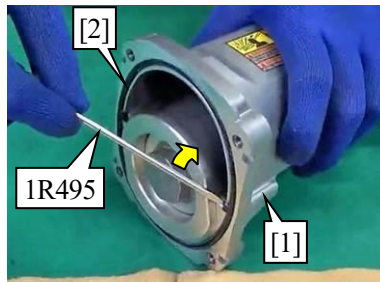

- 4 Remove Seal ring [2] from Chamber [1] with 1R495.

Fig. 42

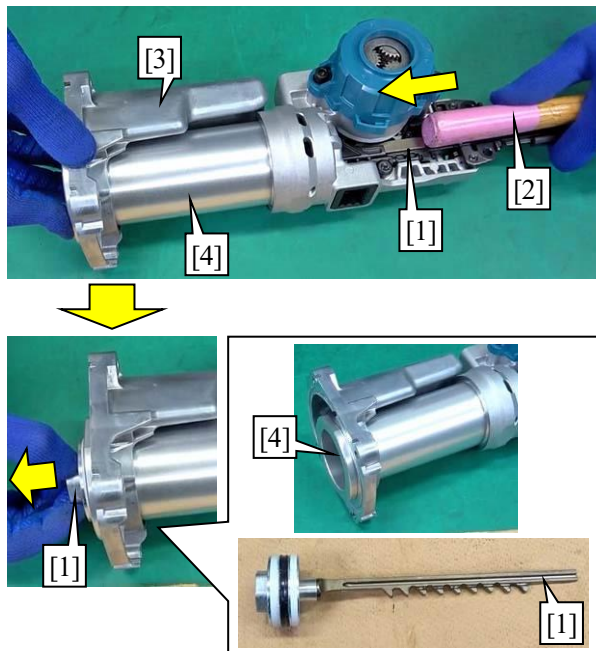

- 5 Push out Driver [1] from the top side, and when it moves, pull it out from the opposite side.

Tips

Use the grip of a hammer [2] or a piece of wood to push out Driver [1] to prevent its top from wearing out.

Note

- When pushing out Driver [1], if you grasp Chamber section [3], it will come off from Cylinder [4], so grasp the rear side of Cylinder [4] or the cylindrical section.
- Cylinder [4] is an aluminum part and Driver [1] is an iron part. If Driver [1] comes into contact with the inside of Cylinder [4], the inside of Cylinder [4] will be damaged. Therefore, be careful not to let Driver [1] come into contact with the inside of Cylinder [4] and pull it out slowly and horizontally.

Fig. 43

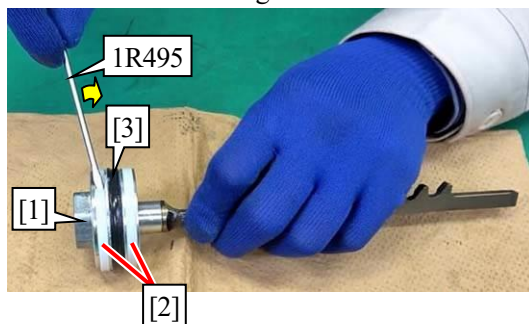

- 6 Spread and remove the notches of Slide rings [2] (2 pcs) from Driver [1] with 1R495, then lift up and remove X-ring 40 [3] with 1R495.

Fig. 44

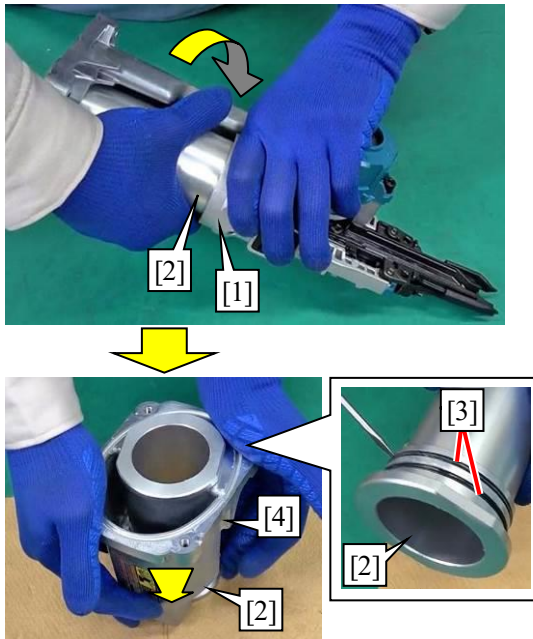

- 7 Remove Cylinder [2] (with O rings 55 [3] (2 pcs) from Nose [1] by turning it counterclockwise.

Tips

If it is hard to turn, hold Nose section [1] in Vise or grip the flats of Cylinder [2] with an adjustable wrench to turn and remove Cylinder [2].

- 8 While supporting Cylinder [2] with a workbench, push and remove Chamber [4].

Fig. 45

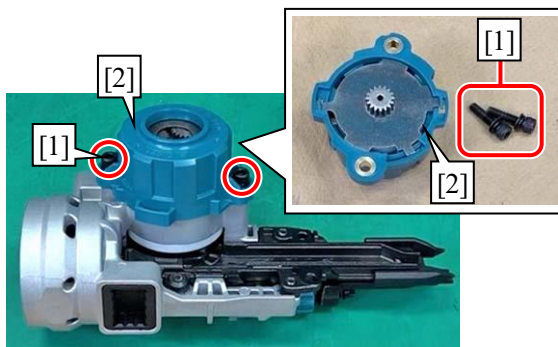

- 9 Remove H.S.H.bolts M5x20 [1] (2 pcs), then remove Gear assembly [2].

Note

Replace Gear assembly [2] as a set.

Fig. 46

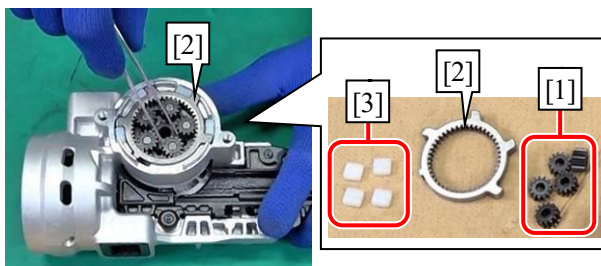

- 10 Remove Spur gears 13 [1] (5 pcs), Internal gear 44 [2] and Gear cushions [3] (4 pcs).

Note

Removed Gear cushions [3] (4 pcs) are different in wear level, and if they are assembled in different positions or orientations when reused, there is a possibility that their parts won't perform well enough. So, when you remove them, replace all of them with new ones.

Fig. 47

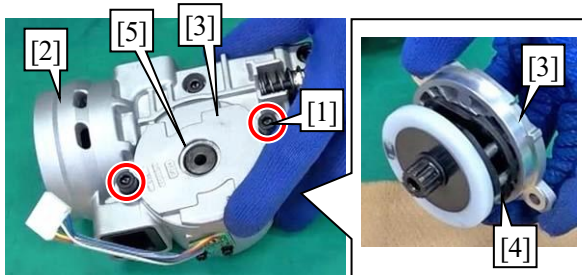

- 11 Remove H.S.H.bolts M5x20 [1] (2 pcs), then lift up and remove Lifter cap [3] from Nose [2].

Tips

Lifter [4] may be left on Nose side [2] depending on the fit of Bearing 6002DDW [5], but even if Lifter [4] is left on Nose side [2], lift up and remove Lifter [4] by hand easily.

Fig. 48

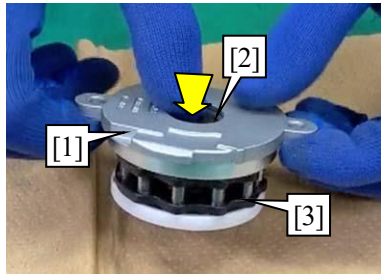

■ When Lifter and Lifter cap are removed together.

12 Hold Lifter cap [1] and push Lifter shaft [2] in the center with your hand to remove Lifter [3].

Tips

If Lifter [3] cannot be removed by hand, use Arbor press to remove it.

Fig. 49

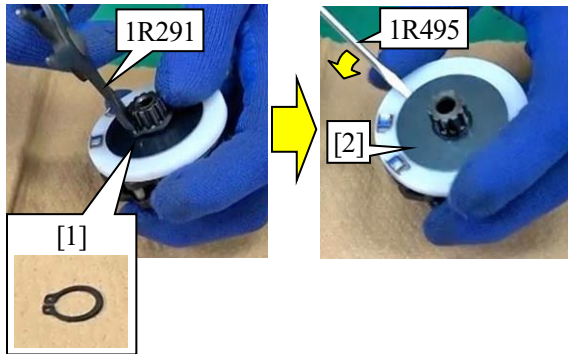

13 Remove Retaining ring S-13 [1] with 1R291, then remove Flat washer [2] with 1R495.

Fig. 50

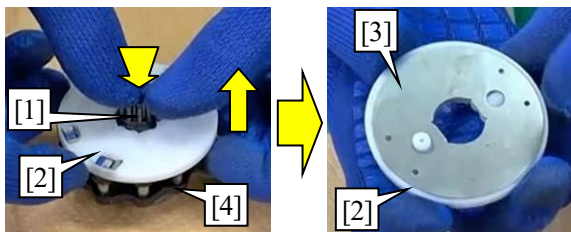

14 While pressing Lifter shaft [1], lift up and remove Holder [2], then remove Pin cover [3] from Holder [2].

Tips

Pin cover [3] can be removed together with Holder [2] because a magnet is equipped to Holder [2].

Note

If Lifter [4] is lifted up together when removing Holder [2], Compression spring 4 tends to pop out. Therefore, lift up Holder [2] only so that Lifter [4] does not lift up as much as possible.

Fig. 51

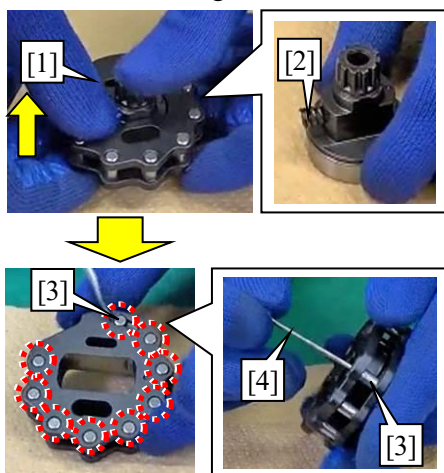

15 Lift up and remove Lifter [1], then remove Compression spring 4 [2].

16 Remove Pins 5 [3] (9 pcs).

Tips

If grease is left on Pins 5 [3] (9 pcs), it cannot be lifted up with a magnetized screwdriver, so remove it by pushing it out from the back with an appropriate Pin jig [4].

Note

Be careful not to pop out Compression spring 4 [2] when removing Lifter [1].

Fig. 52

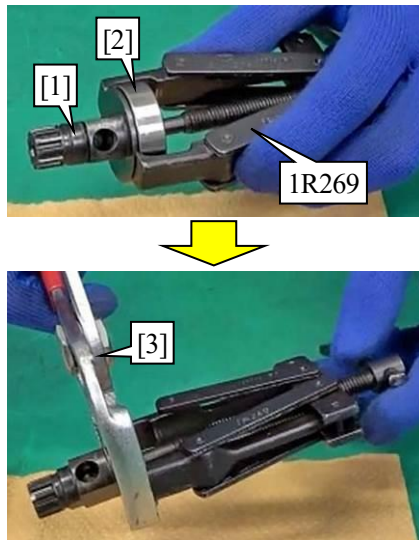

■ When removing Bearing 6002DDW from Lifter shaft

- 17 Remove Bearing 6002DDW [2] from Lifter shaft [1] with 1R269.

Tips

Because there is no gap between Lifter shaft [1] and Ball bearing 6002DDW [2], set 1R269 and turn it while holding its jaws firmly with the water pump pliers [3] so that its jaws enter into the gap and can pull out Ball bearing 6002DDW [2].

Fig. 53

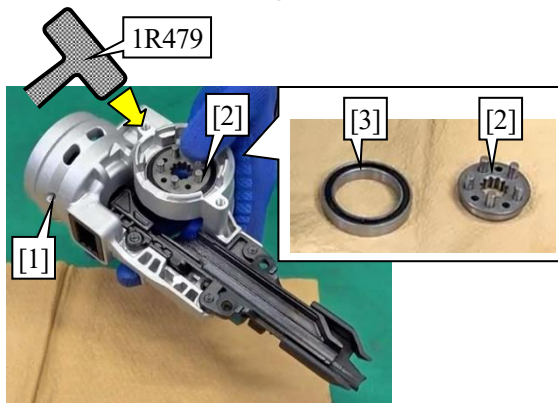

- 18 Remove Carrier [2] and Ball bearing 6806DDW [3] by tapping Nose [1] with 1R479.

Fig. 54

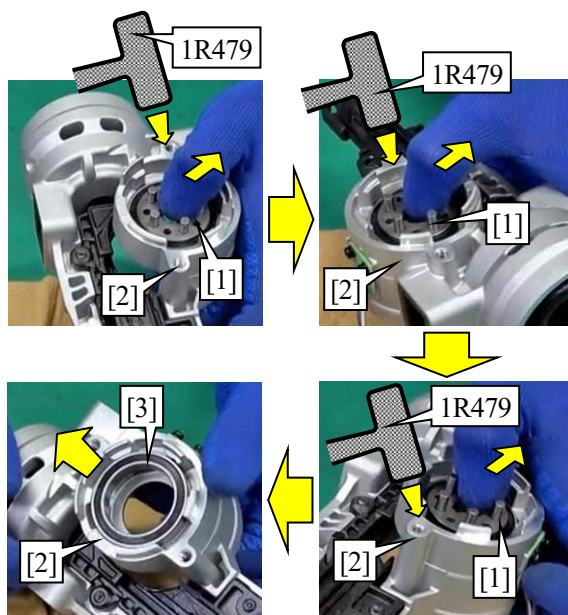

■ If only Carrier falls off.

- 19 Insert Carrier [1] again, then hold Carrier [1] by prying it aside with your thumb, and then tap Nose [2] with 1R479.
- 20 Similarly, press Carrier [1] horizontally in three directions and tap Nose [2] with 1R479 to remove Carrier [1] and Ball bearing 6806DDW [3].

Tips

Once Ball bearing 6806DDW [3] is raised until it reaches the top of the bearing assembling portion of Nose [2], the bearing assembling portion is not firmly engaged. Therefore, lift and remove Ball bearing 6806DDW [3] straight by hand.

Fig. 55

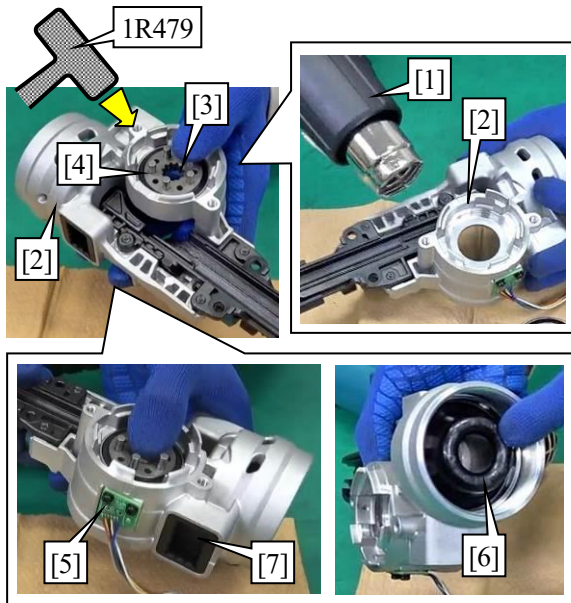

■ If Ball bearing 6806DDW cannot be removed even by prying up Carrier.

- 21 Warm Nose [2] with a heat gun [1], then remove Carrier [3] and Ball bearing 6806DDW [4] by tapping Nose [2] with 1R479.

Tips

If Nose [2] is warmed from the outside where Ball bearing 6806DDW [4] is assembled with a heat gun [1], the heat will not be transmitted easily to Ball bearing 6806DDW [4], and Nose [2] will be easy to spread.

Note

When using a heat gun [1], remove Sensor circuit [5], Front cushion [6] and Side cushions [7] (2 pcs) which are sensitive to heat. (Fig. 59)

Fig. 56

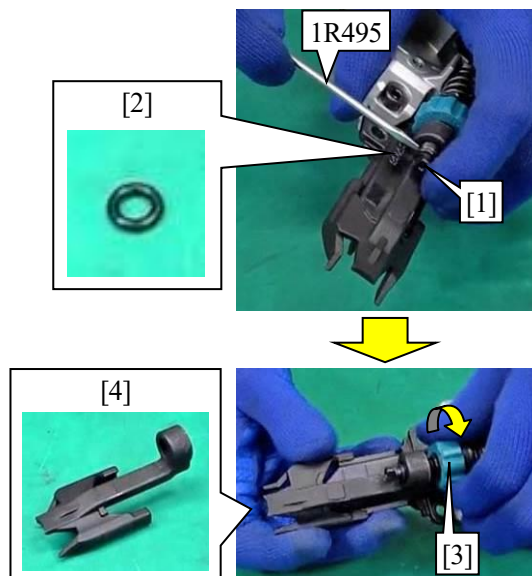

- 22 Remove O ring 5 [2] from the top of Adjuster shaft [1] with 1R495, then remove Contact top [4] by turning Adjuster dial [3] counterclockwise.

Fig. 57

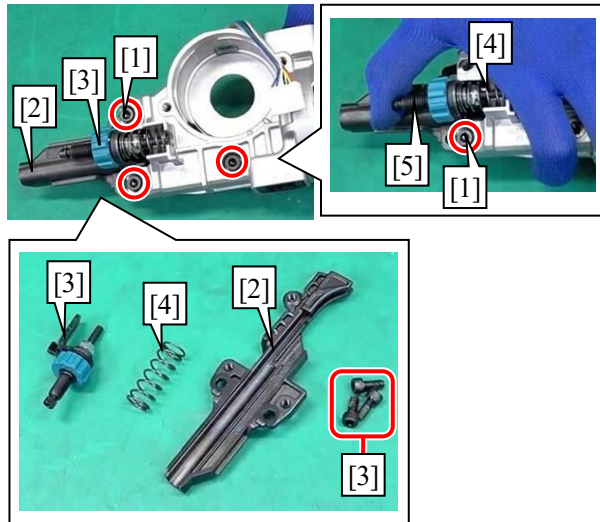

23 Remove H.S.H.bolts M5x12 [1] (3 pcs), then remove Driver guide [2].

24 Remove Adjuster section [3] and Compression spring 12 [4].

Note

Remove the last one of H.S.H.bolt M5x12 [1] while holding Adjuster shaft [5] to prevent the parts from popping out due to the tension of Compression spring 12 [4].

Fig. 58

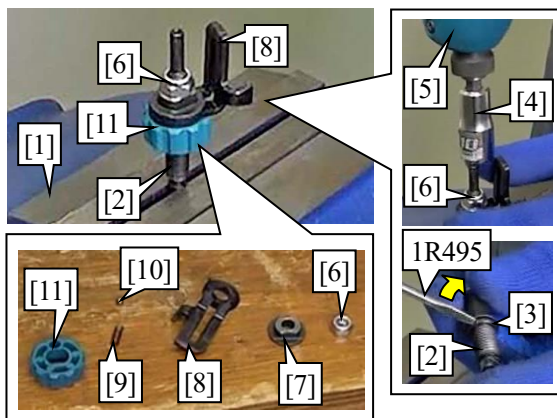

25 Hold the flats of Adjuster shaft (with O ring 5 [3]) in Vise [1], then remove Hex.lock nut M6-10 [6] with Socket bit 10 [4] and an impact driver [5], and then remove the following parts:

- Adjuster sleeve [7]
- Contact arm [8]
- Compression spring 3 [9]
- Steel ball 3.5 [10]
- Adjuster dial [11]

Fig. 59

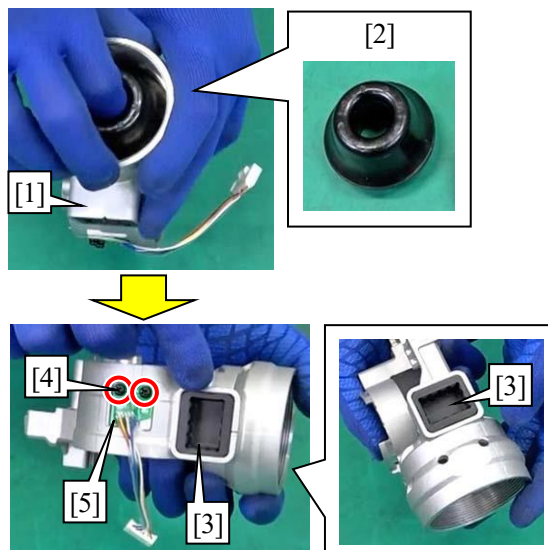

26 Remove Front cushion [2] by inserting finger into Front cushion [2] from Nose [1] and pulling it to one side, then pull and remove Side cushions [3] (2 pcs).

27 Remove Pan head screws M3x8 [4] (2 pcs), then remove Sensor circuit [5].

6-4-2 Assembling

Fig. 60

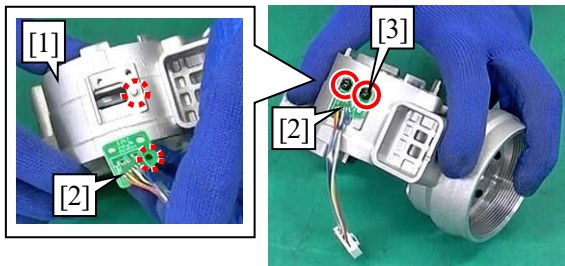

- 1 Align the screw holes (2 positions) of Nose [1] and its protrusion with the holes (3 positions) of Sensor circuit [2], then assemble Sensor circuit [2] with Pan head screws M3x8 [3] (2 pcs).

Fig. 61

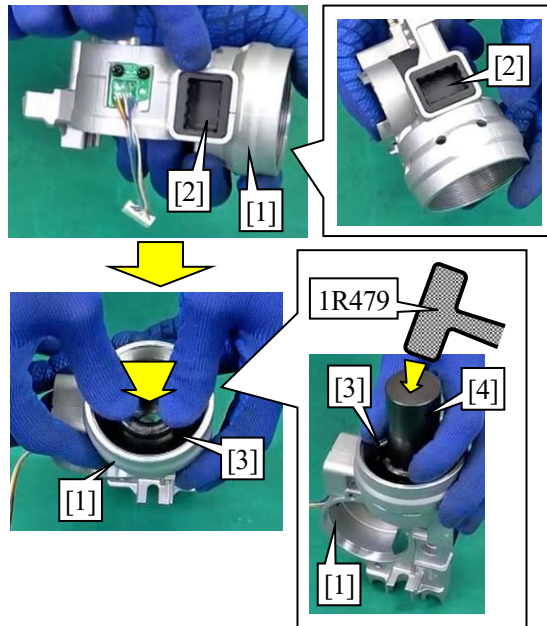

- 2 Assemble Side cushions [2] (2 pcs) to Nose [1] with their concaved side facing outward, then insert Front cushion [3] straight into the bottom.

Tips

If Front cushion [3] is hard to insert by hand, tap it with 1R479 with an appropriate Round bar jig [4] or an appropriate Pipe jig, and if it cannot be inserted further, press-fit it with Arbor press in this state.

Note

Check that Front cushion [3] is inserted into the bottom of Nose [1].

Fig. 62

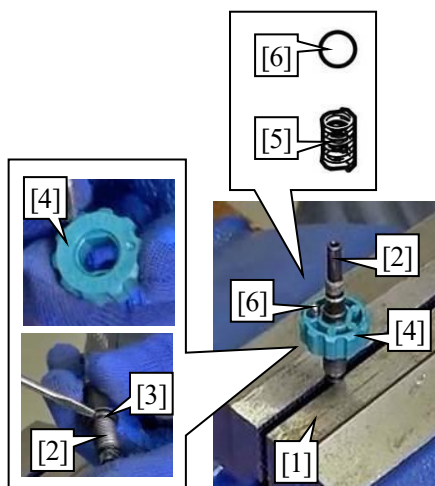

- 3 Hold the flats of Adjuster shaft [2] (with O ring 5 [3]) in Vise [1], then assemble Adjuster dial [4] to Adjuster shaft [2] (with O-ring 5 [3]) by aligning their flats with the side without the holes of Adjuster dial [4] facing downward.
- 4 Assemble Compression spring 3 [5] and Steel ball 3.5 [6] into the hole of Adjuster dial [4].

Tips

If Steel ball 3.5 [6] falls off and it is difficult to assemble, you may apply grease to prevent it from falling off.

Fig. 63

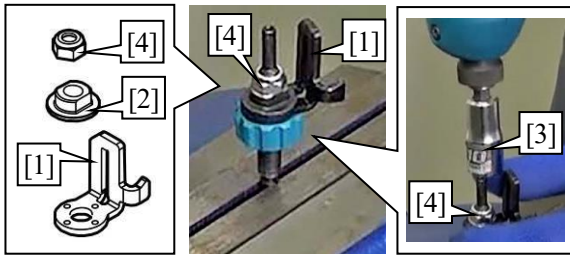

- 5 Assemble Contact arm [1] with its bent side facing upward.
- 6 Assemble Adjuster sleeve [2] with its flat side facing Contact arm [1] side, then tighten Hex.lock nut M6-10 [4] with Socket bit 10 [3] and an impact driver.

Fig. 64

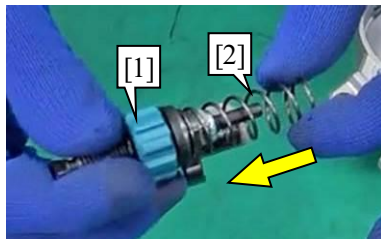

- 7 Assemble Compression spring 12 [2] to Adjuster dial section [1].

Fig. 65

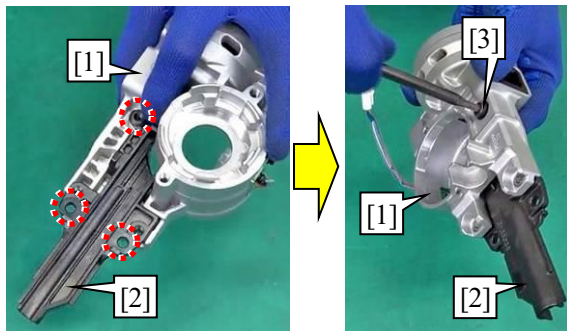

- 8 Align the positions of the screw holes (3 positions) of Driver guide [2] with the holes (3 positions) of Nose [1] from the top, then lightly tighten H.S.H bolt M5x12 [3] from Nose side [1].

Tips

Tighten H.S.H.bolt M5x12 [3] at one position in order to align the positions. However, do not fully seat it, leaving Driver guide [2] rattling.

Fig. 66

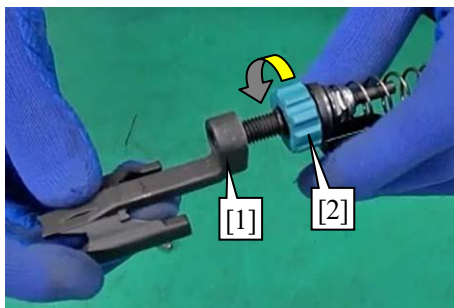

- 9 Screw Adjuster dial part [2] into Contact top [1] 1 or 2 times.

Fig. 67

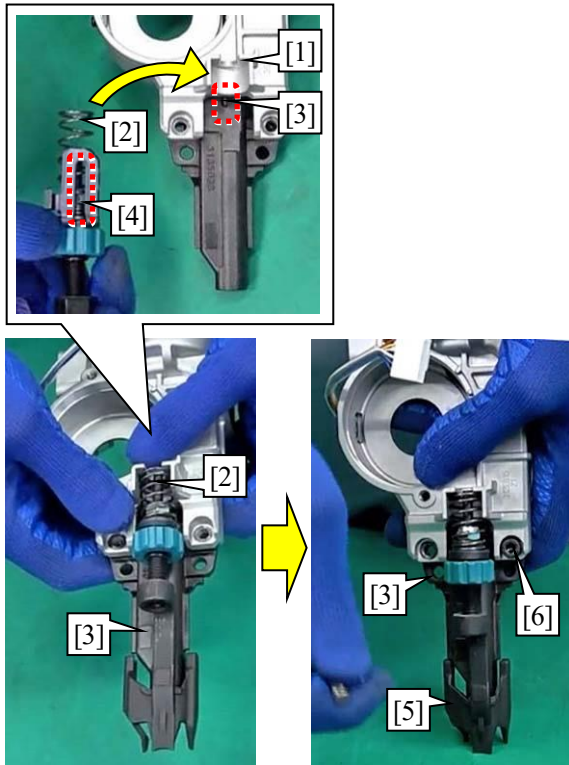

10 Align the position of Compression spring 12 [2] with the U-shape of Nose [1], then lift up Driver guide [3] to assemble it with the orientation of the protrusion of Driver guide [3] fits into the groove of Contact arm [4].

11 While pressing Contact top [5] against a workbench to align the screw holes of Driver guide [3] firmly, tighten H.S.H.bolt M5x12 [6] by turning the bit manually.

Tips

Tighten H.S.H.bolt M5x12 [6] at one position to prevent Driver guide [3] from falling off.

Note

Hold Contact arm [4] and Driver guide [3] firmly so that their shapes align, then press Contact top [5] against a workbench.

Fig. 68

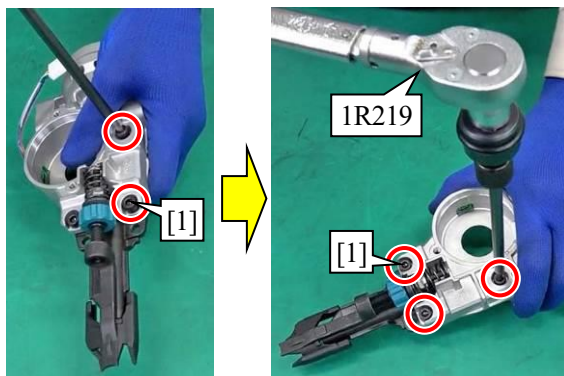

12 Tighten the remaining H.S.H.bolts M5x12 [1] (2 pcs), then finally tighten H.S.H.bolts M5x12 [1] (3 pcs) to the specified torque with 1R219 (Torque wrench).

Fig. 69

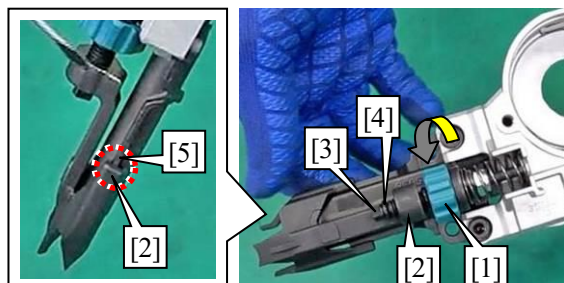

13 Turn Adjuster dial [1] to assemble Contact top [2] to the bottom, then assemble O ring 5 [4] into the groove on the top of Adjuster shaft [3].

Note

When assembling Contact top [2], align the U-shaped portions on both sides of Contact top [2] with the rails on both sides of Driver guide [5]. If they are not fit properly, Contact top [2] cannot be inserted all the way.

Fig. 70

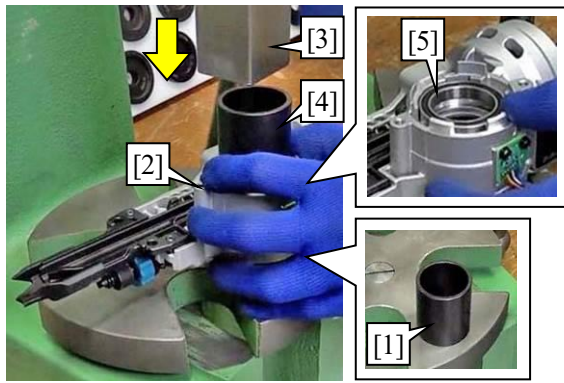

- 14** Support Nose [2] with an appropriate Pipe jig [1], then press-fit Ball bearing 6806DDW [5] with Arbor press [3] and an appropriate Pipe jig [4].

Fig. 71

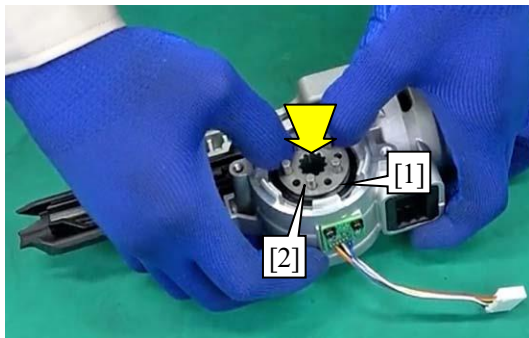

- 15** Assemble Carrier [2] to the inner surface of Ball bearing 6806DDW [1].

Tips

- If it is difficult to insert Carrier [2], use Arbor press.
- If Carrier [2] is tilted, Carrier [2] can be pushed from the rear side, so remove it and insert it straight once again.

Fig. 72

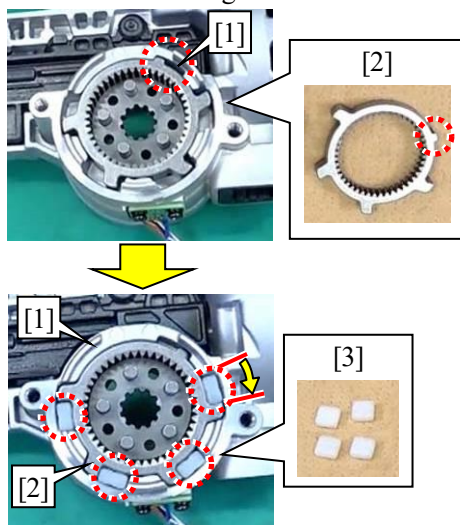

- 16** Align the small protrusion of Internal gear 44 [2] with the shallow concave of Nose [1] to assemble Internal gear 44 [2].

- 17** Turn Internal gear 44 [2] clockwise to bump it against Nose [1], then assemble Gear cushions [3] (4 pcs) to the gap between the large protrusions (4 positions) of Internal gear 44 [2] and Nose [1].

Note

Removed Gear cushions [3] (4 pcs) are different in wear level, and if they are assembled in different positions or orientations when reused, there is a possibility that their parts won't perform well enough. So, when you remove them, replace all of them with new ones.

Fig. 73

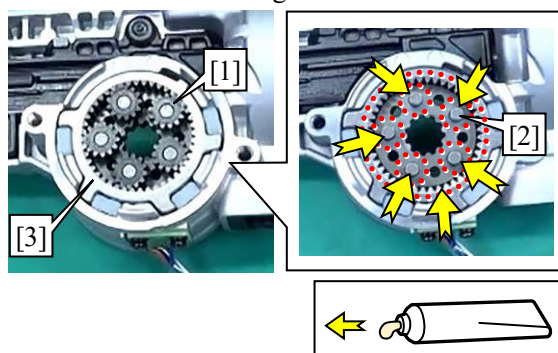

- 18** Assemble Spur gears 13 [1] (5 pcs).

Note

Apply a small amount of the specified grease to the entire pins (5 positions) of Carrier [2] and the teeth of Internal gear [3] before assembling Spur gears 13 [1] (5 pcs).

Fig. 74

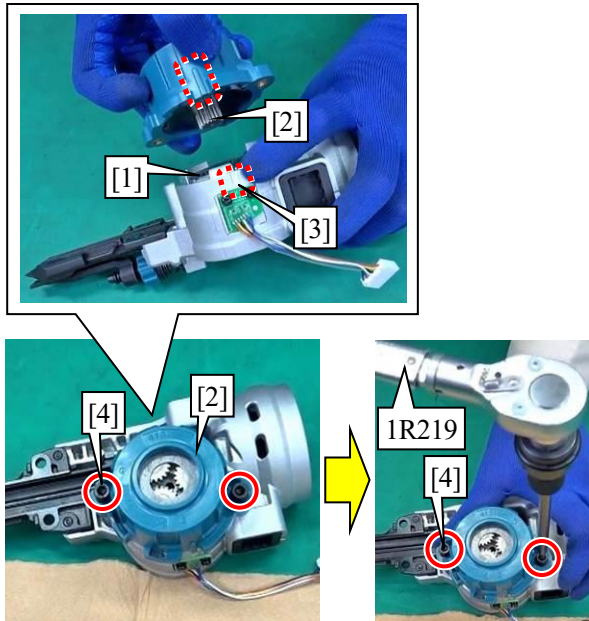

- 19** Engage Spur gear 13 [1] with the center gear of Gear assembly [2], then assemble them by aligning the screw hole of Nose [3] with the screw hole of Gear assembly [2].

Note

Assemble in a position where the concave shape of positioning of Nose [3] aligns with the convex shape of Gear assembly [2].

- 20** Tighten H.S.H. bolts M5x20 [4] (2 pcs) firmly to the specified torque with 1R219.

Fig. 75

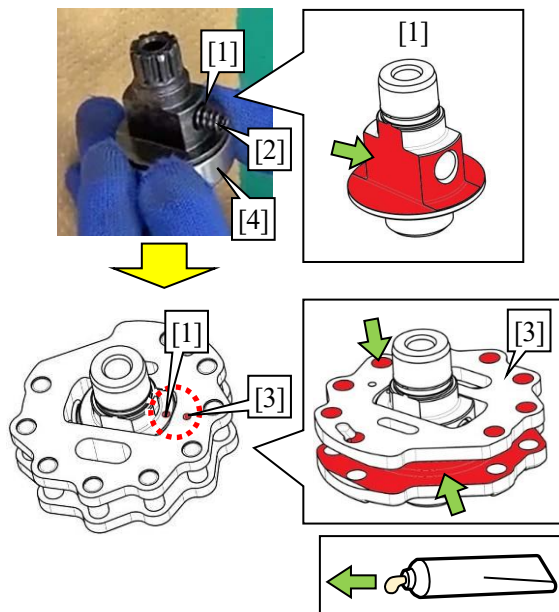

- 21** Assemble Compression spring 4 [2] into the hole of Lifter shaft [1], then assemble Lifter [3] by aligning the mark on Lifter [3] with that of Lifter shaft [1].

Note

- Check that Bearing 6002DDW [4] is assembled to Lifter shaft [1].
- Apply a small amount of the specified grease to the flat side surfaces (2 positions), the rounded side surfaces (2 positions) and the entire flange surface of Lifter shaft [1].
- Apply a small amount of the specified grease to the inside, on the bottom of both sides, and in the grooves where the pins insert of Lifter [3].
- Check that Compression spring 4 [2] is compressed and assembled properly.

Fig. 76

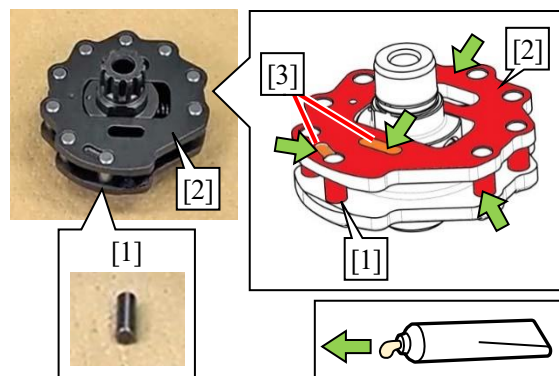

- 22** Insert Pins 5 [1] (9 pcs).

Note

- Apply a small amount of the specified grease to the outer surface of Pins 5 [1], the entire upper surface of Lifter [2] on the side where Pins 5 [1] are inserted and the grease reservoirs [3] (2 positions).
- Insert the specified grease into reservoirs [3] (2 positions) so that the grease fills sufficiently.

Fig. 77

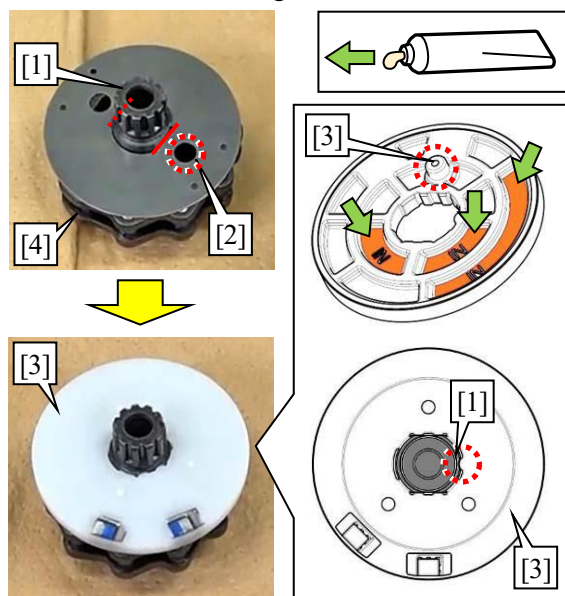

23 Align the flats of Lifter shaft [1] with the flats of the center hole of Pin cover [2], then assemble Pin cover [2].

24 Face the grooved side of Holder [3] toward Pin cover [2], then assemble Holder [3] to Lifter shaft [1] by aligning the concave shape of Lifter shaft [1] with the convex shape of Holder [3].

Tips

- Align the flats of Lifter shaft [1] with the flats of Holder [3].
- Align the protrusion of Holder [3] with the hole of Pin cover [2] that is not covered by Lifter [4] among the holes (2 positions) of Pin cover [2].

Note

Apply the specified grease to the portion of Holder [3] marked with "IN" on the side with the groove. Apply a sufficient amount of grease because it affects the durability of the machine.

Fig. 78

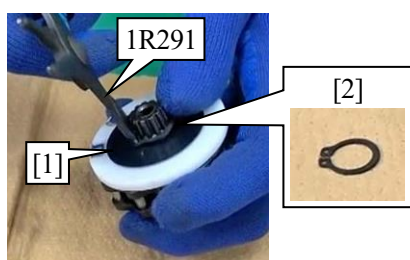

25 Assemble Flat washer 14 [1], then assemble Retaining ring S-13 [2] with 1R291.

Note

Retaining ring S-13 [2] has a flat edge side and a rounded edge side. Assemble it so that the rounded edge side faces toward Flat washer 14 [1].

Fig. 79

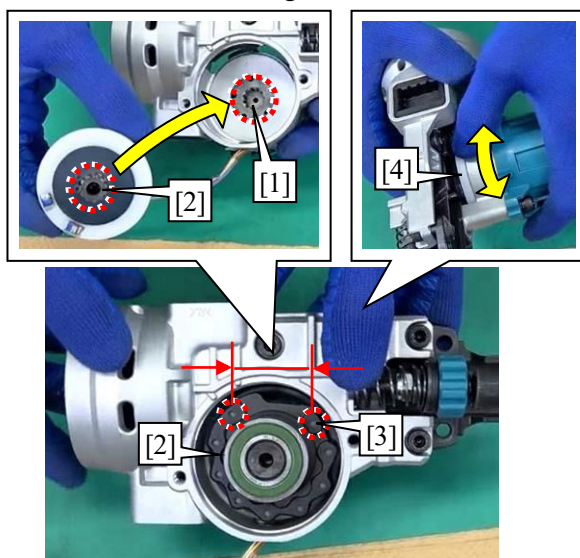

26 Align the knurled edge of Lifter [2] with Carrier [1] to assemble it.

Note

- Lifter [2] should be assembled so that the large distance between Pins 5 [3] of Lifter [3] is on the upper side of the machine so that Pins 5 [3] of Lifter [2] do not interfere with Driver for the time when assembling Driver.
- When Lifter cap is assembled to Lifter [2], it is difficult to see the position of Pins 5 [3] of Lifter [2] and to adjust the position, but Holder [4] is visible from the back side. Therefore, turn Holder [4] to adjust the position.

Fig. 80

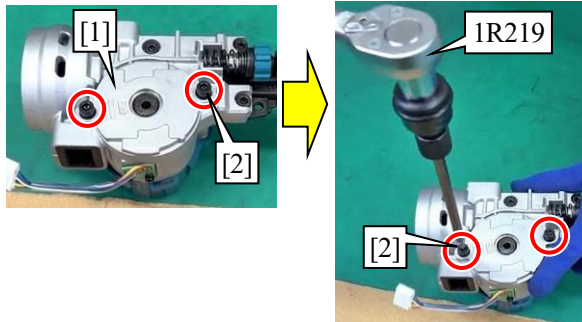

- 27 Align the screw holes of Lifter cap [1] with those of Nose to assemble it.

Tips

Bearing 6002DDW is a little tightly assembled, so press down Lifter cap [1] firmly to assemble it.

- 28 Tighten H.S.H.bolts M5x20 [2] (2 pcs), then finally tighten them firmly to the specified torque with 1R219.

Fig. 81

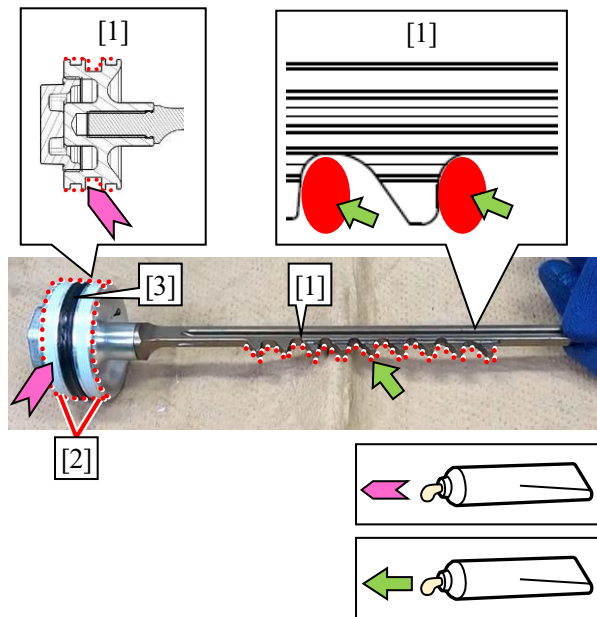

- 29 Assemble Slide rings [2] (2 pcs) and X-ring 40 [3] to the three grooves of Driver [1].

Tips

Slide rings [2] (2 pcs) have notches, so spread and assemble them.

Note

- Apply a small amount of the specified grease to the three grooves of Driver [1] before assembling Slide rings [2] (2 pcs) and X-ring 40 [3].
- After assembling Slide rings [2] (2 pcs) and X-ring 40 [3], apply a small amount of the specified grease onto them.
- Apply the specified grease to the jagged portions of Driver [1]. Apply a sufficient amount of grease because it affects the durability of the machine. In particular, apply a sufficient amount of grease to the jagged portions of Driver [1] that are facing the tip of the machine and that come into contact with Pins 5 during winding.

Fig. 82

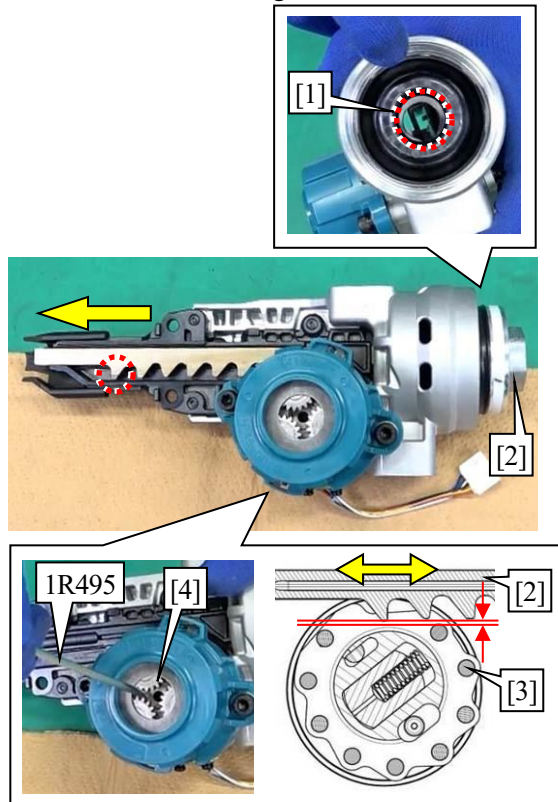

30 Insert Driver [2] from Front cushion side [1] to assemble it.

Note

- Check that Pin 5 [3] is not visible by looking inside from Front cushion [1] side.
- If Pin 5 [3] is visible, adjust Spur gear 13 [4] by turning it with 1R495 to prevent the teeth of Driver [2] from touching Pin 5 [3] even if Driver [2] is inserted.
- Be careful that the top tooth of Driver [2] is higher than the other teeth.
- When adjusting the position of Pin 5 [3], be careful because Spur gear 13 [4] turns in only one direction. If you turn too much, you will have to turn it one more time to return it to its original position.

Fig. 83

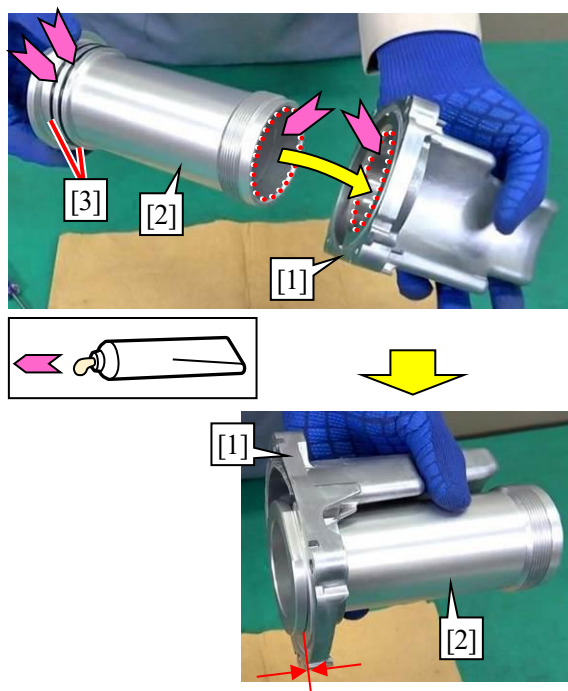

31 Assemble Cylinder [2] by inserting it into Chamber [1] straightly so that O rings 55 [3] (2 pcs) on Cylinder [2] come to the inner wall portion of Chamber [1].

Note

- Before assembling Cylinder [2], apply a small amount of the specified grease to the inner wall of Cylinder [2], the inner wall of Chamber [1], and O rings 55 [3] (2 pcs).
- When assembling Cylinder [2] to Chamber [1], assemble Cylinder [2] straightly to prevent O rings 55 [3] (2 pcs) from falling off, then check that there is no gap between Chamber [1] and Cylinder [2].
- After assembling Cylinder [2], check that O rings 55 [3] (2 pcs) are not popped out. If they are popped out, pull out Cylinder [2] and insert it straightly once again.

Fig. 84

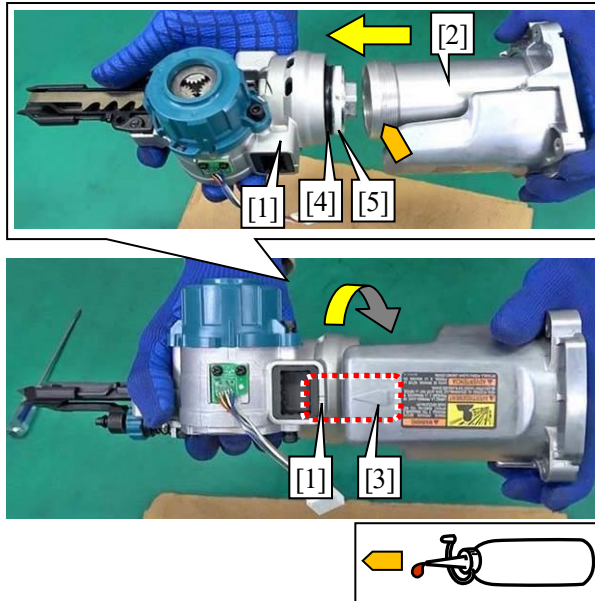

- 32** Insert Cylinder [2] into Nose [1], then tighten Cylinder [2] firmly by turning it clockwise.
- 33** Adjust the position of Chamber [3] by turning it clockwise until the concave portion of Nose [1] aligns with the triangle mark of Chamber [3].

Tips

Cylinder [2] may be difficult to insert because of X-ring 40 [4] and Slide ring [5], but push it in firmly.

Note

- Apply a small amount of the specified lubricant to the threads of Cylinder [2] to prevent galling.
- When aligning the positions of Chamber [3], if you turn Chamber [3] counterclockwise to align the position, Cylinder [2] will loosen. Therefore, turn Cylinder [2] clockwise to align the position.

Fig. 85

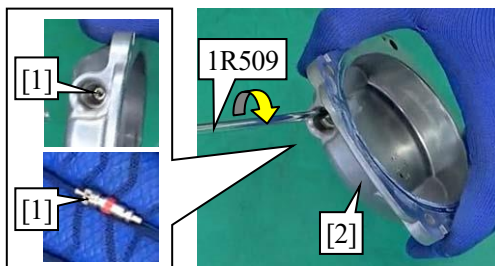

- 34** Insert Valve core [1] into the hole of Top cap [2] with the threads of Valve core [1] facing outward, then tighten it by turning it clockwise with 1R509.

Note

Tighten Valve core [1] lightly after seated on because too much tightening causes threads to be broken.

Fig. 86

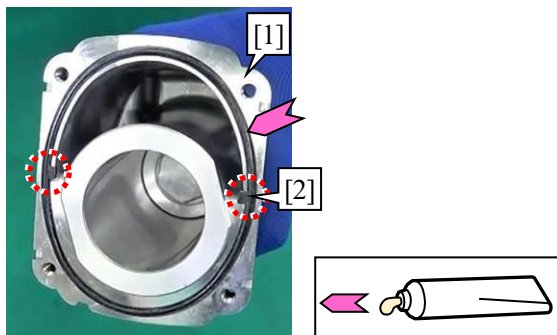

- 35** Align the stoppers of Seal ring [2] with the notches of Chamber [1] to assemble Seal ring [2] into the groove of Chamber [1].

Note

Apply a small amount of the specified grease to Seal ring [2].

Fig. 87

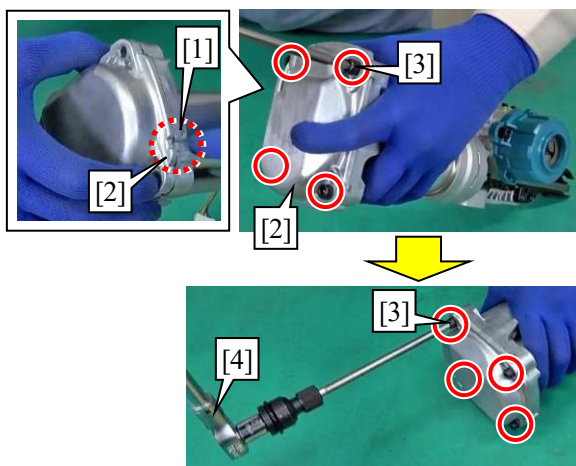

- 36** Align the notch of Chamber [1] with the notch of Top cap [2], then tighten Hex.socket head bolts M6x25 [3] (4 pcs), and then finally tighten them to the specified torque with 1R219.

Note

Injecting compressed air into Chamber [1] should be done just before assembling Housing L to Housing R. ([Fig. 35](#))

7 CIRCUIT DIAGRAM

7-1 Section 1

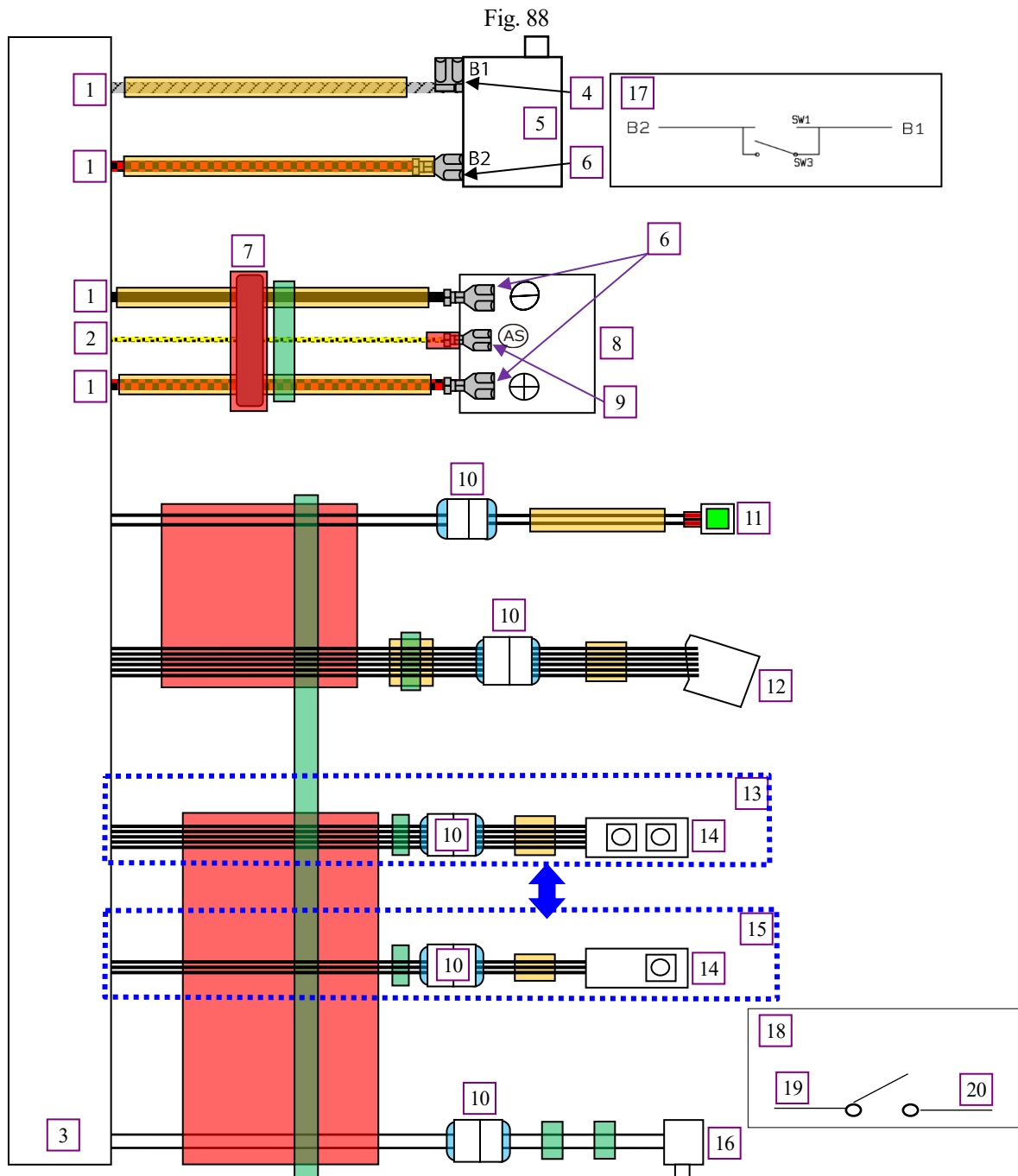

1	AWG14	11	LED circuit
2	AWG22	12	Sensor circuit
3	Controller	13	Specification of mode selectable between "Single nailing" and "Continuous nailing"
4	Flag receptacle with lock (#250, t=0.8)	14	Switch circuit
5	Switch	15	Specification of "Single nailing" only
6	Straight receptacle with lock (#250, t=0.8)	16	Switch unit A (for Contact arm)
7	Line filter (if used)	17	Circuit diagram of Switch
8	Terminal	18	Circuit diagram of Switch unit
9	Straight receptacle (#187, t=0.8)	19	Black
10	Connector	20	Blue

7-2 Section 2

Fig. 89

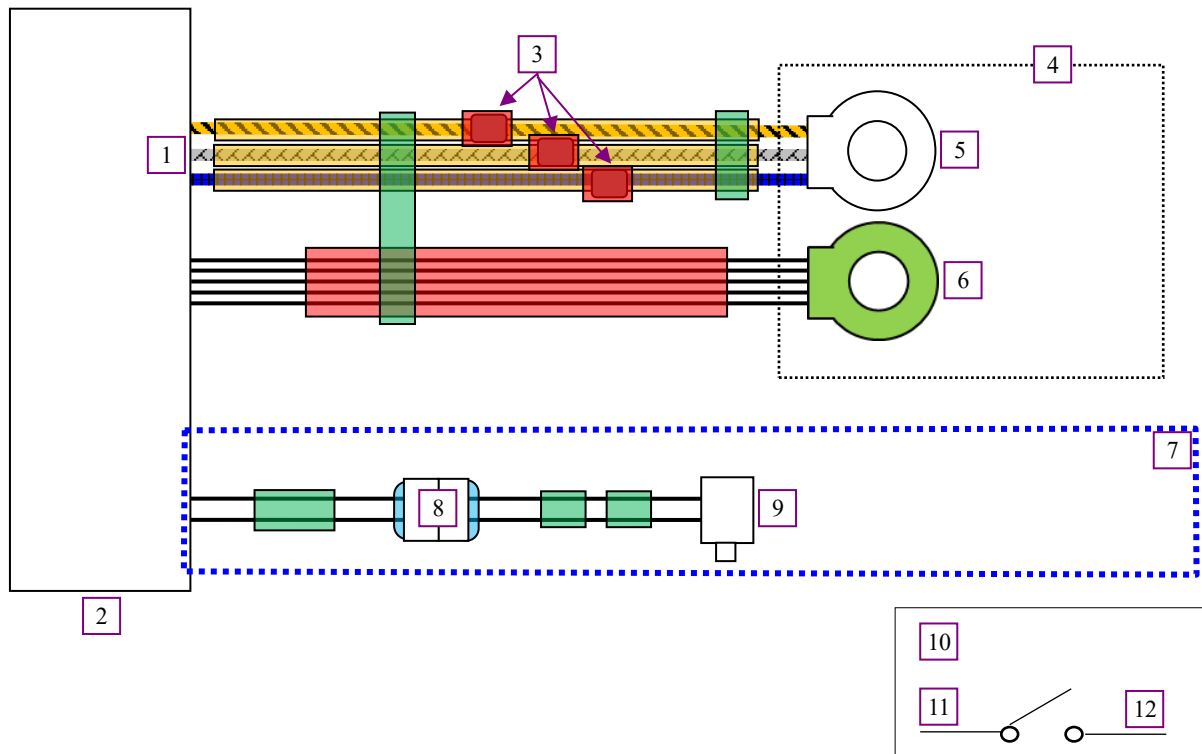

1	AWG14	7	Specification of mode selectable between “Single nailing” and “Continuous nailing”
2	Controller	8	Connector
3	Line filter (if used)	9	Switch unit B (for Trigger)
4	Stator	10	Circuit diagram of Switch for Trigger
5	Terminal unit	11	Black
6	Sensor board	12	Blue

8 WIRING DIAGRAM

8-1 Section 1

Fig.90

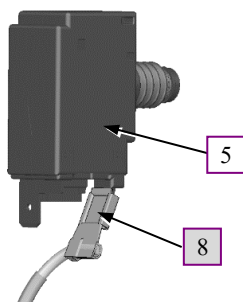
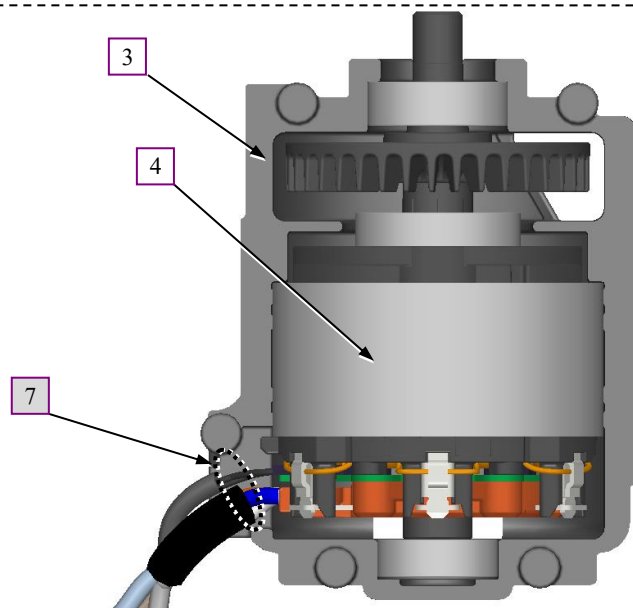
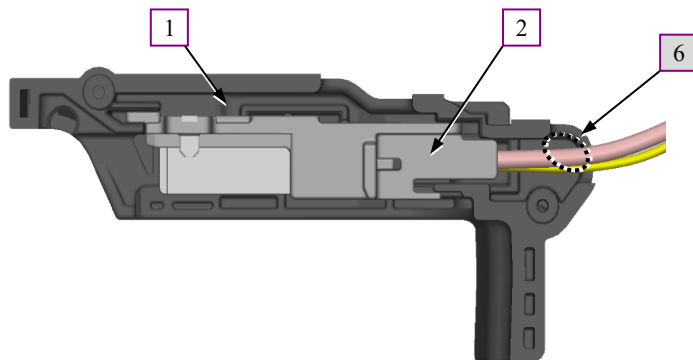

1	Battery holder L	4	Stator
2	Terminal	5	Switch
3	Motor housing L		
6	Fix Controller lead wires for Terminal in this groove.		
7	Fix Stator lead wires in this groove.		
8	Connect Flag receptacle to Switch so that the lead wire comes out as shown.		

8-2 Section 2

Fig.91

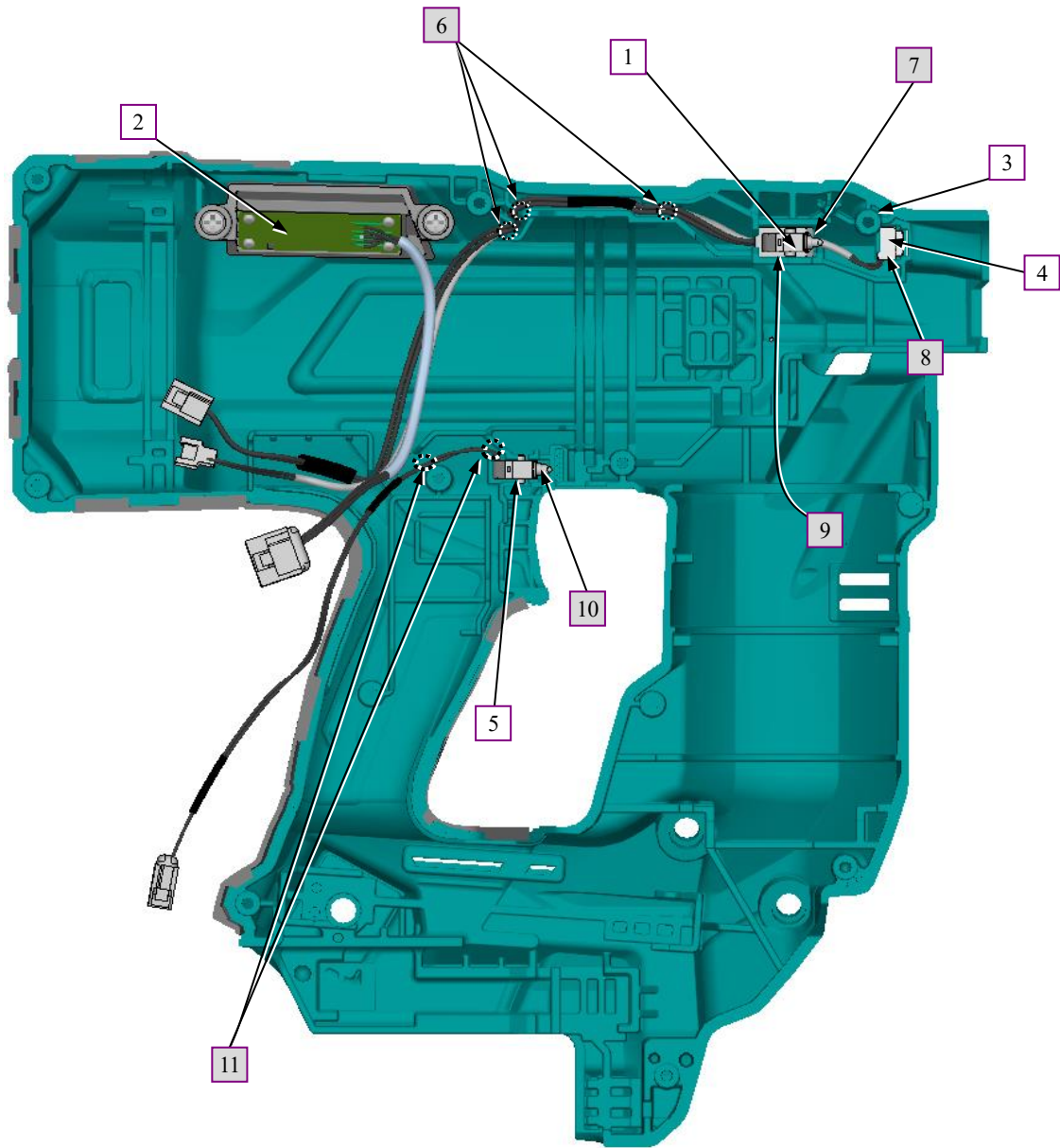

1	Switch unit A (for Contact arm)	4	LED circuit
2	Switch circuit	5	Switch unit B (for Trigger)
3	Boss A		
6	Fix LED circuit lead wires and Switch unit A lead wires in these grooves.		
7	Assemble Switch unit A as shown.		
8	Assemble LED circuit so that their lead wires come out to the opposite side of Boss A.		
9	Put LED circuit lead wires under Switch unit A.		
10	Assemble Switch unit B as shown.		
11	Fix Switch unit B lead wires in these grooves.		

8-3 Section 3

Fig.92

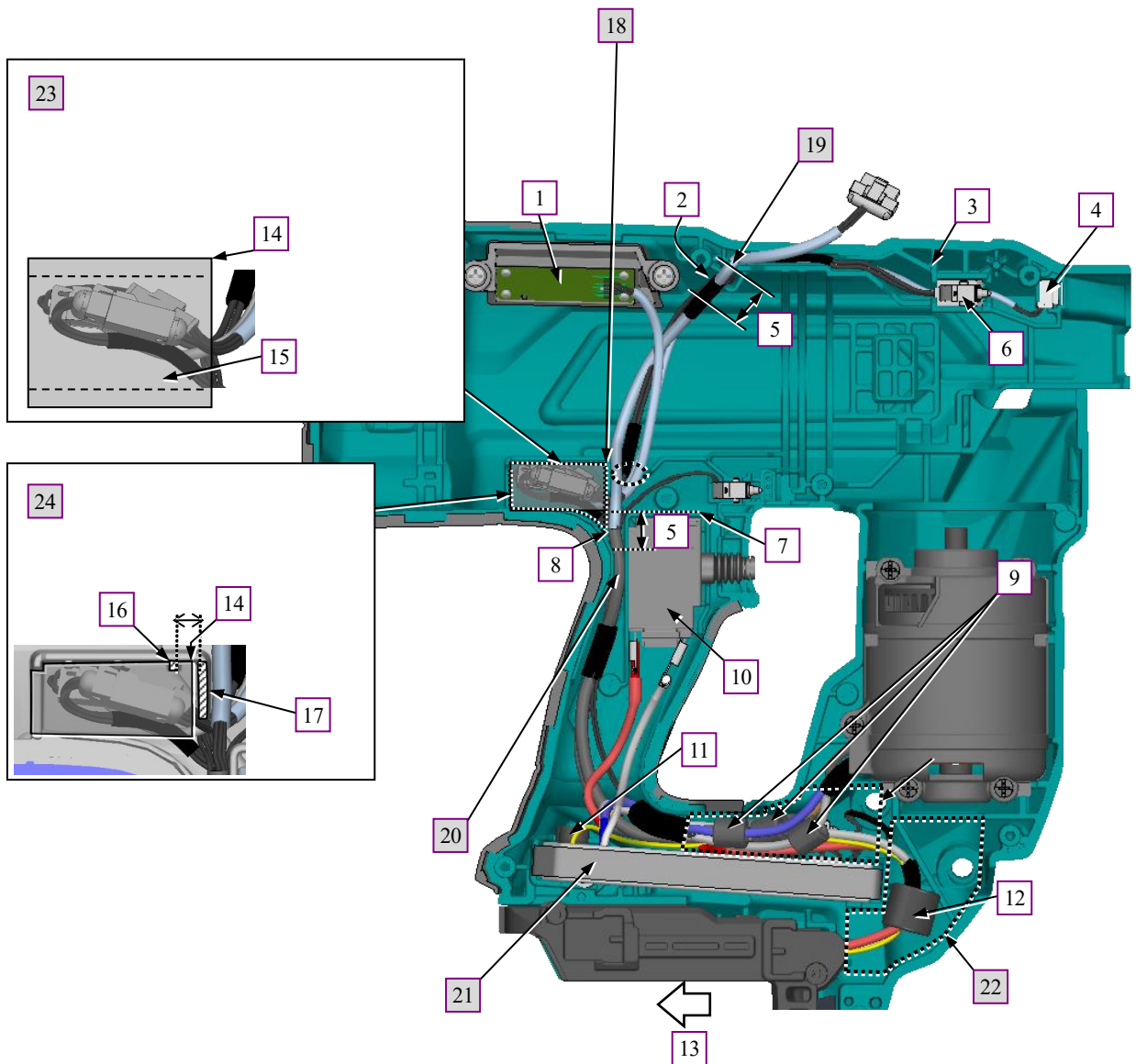

1	Switch circuit	10	Switch
2	End of Tape	11	Capacitor
3	Housing L	12	Line filter B (if used)
4	LED circuit	13	Rear side of machine
5	10mm	14	End of Sponge
6	Switch unit A (for Contact arm)	15	Sponge
7	Rib C	16	Rib A
8	End of Black tube	17	Rib B
9	Line filter A (if used)		
18	Fix the following lead wires in this groove: <ul style="list-style-type: none"> • Controller lead wires for Sensor circuit • LED circuit lead wires • Switch unit A lead wires • Switch circuit lead wires 		
19	Fix Controller lead wires for Sensor circuit in this groove so that the end of the tape is positioned within 10mm from the groove.		
20	Place Line filter A in this space.		
21	Place the end of Black tube on Controller lead wires so that it is positioned within 10mm from Rib C.		
22	Assemble Controller to Housing L so that its capacitor faces toward the rear side of machine.		
23	Place Line filter B in this space.		
24	Place Connectors for Switch circuit/Switch unit A/LED circuit in Sponge as shown below, then place them in this space.		
25	Place Sponge in Housing L so that its end comes between Rib A and Rib B as shown below.		

8-4 Section 4

Fig.93

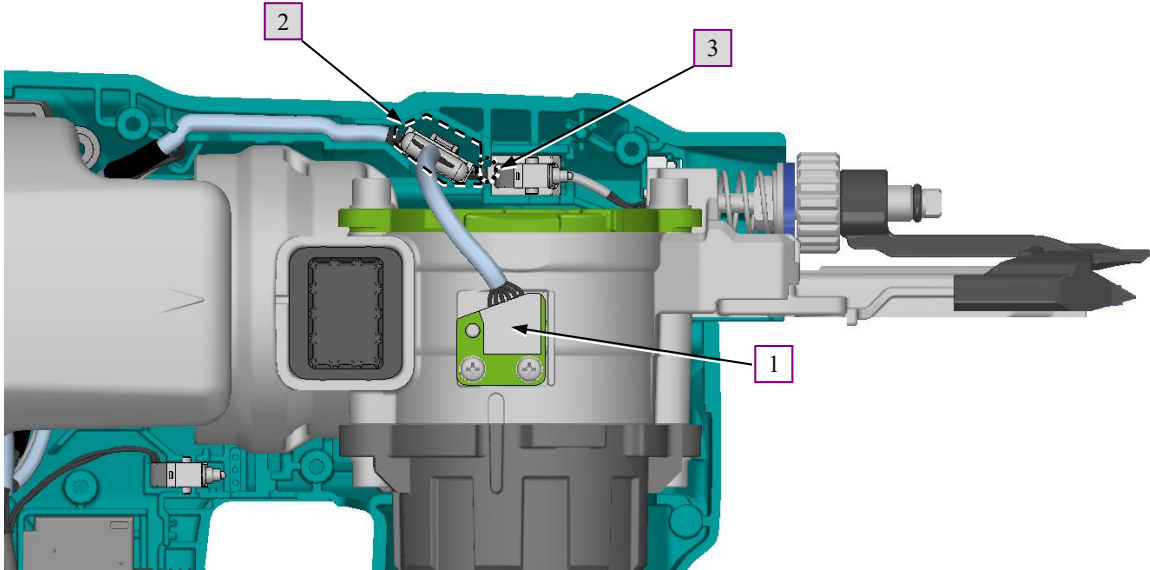

1	Sensor circuit
2	Place Connector for Sensor circuit in this space.
3	Be careful not to put Sensor circuit lead wires in this groove.

9 TROUBLESHOOTING

Whenever you find any trouble in your machine, first, see this list to check the machine for solution.

9-1 Note for Repairing

The content may vary depending on the model.

- 1 Use a full charged battery which has a star mark.
- 2 When Housing is disassembled, check the conditions of the electrical parts (Mechanical lock, Adherence of iron powder to Motor section, Disconnection of Connectors, Pinching and braking of Lead wires, Assembling of Stator, Connection of Terminal and Battery, etc.).
- 3 Be sure to test the machine 10 times to correctly diagnose functions such as Switch etc.
- 4 Use the following Repairing tools for diagnosing LED and Switch.

Repairing tools	Purpose
1R402	For checking variable resistance value or electrical continuity at contact points
1R402-B	
1R412	For checking whether LED lights up
1R413	For checking variable resistance value or electrical continuity at contact points

9-2 Test for checking the short-circuit in FET (Field Effect Transistor) of controller

Fig.94



- 1 Set Digital tester (1R402) to Diode mode.

Fig.95

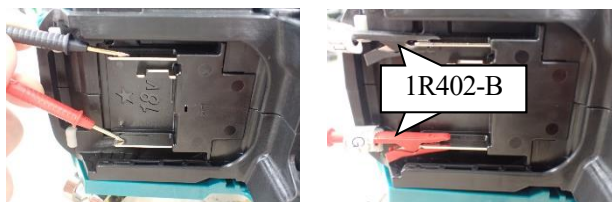

- 2 Connect Black probe to the plus pole of Terminal, and Red probe to the minus pole.

Tips

By attaching 1R402-B to each probe of 1R402, you can make your hands free for easier check.

Note

Be careful not to reverse them. The reversed contacts could spoil the test.

- 3 Wait until the figure on Tester gets stable. Controller is in order if Tester indicates $1.1 \pm 0.1V$. If Tester indicates any other voltage, Controller is broken. Replace it with a new one.

10 Flowchart for Troubleshooting

Check the items in the following flowchart in order from the top to bottom. Description of the item is referred to CIRCUIT DIAGRAM. After corrective action, return to the start of Troubleshooting and re-check again.

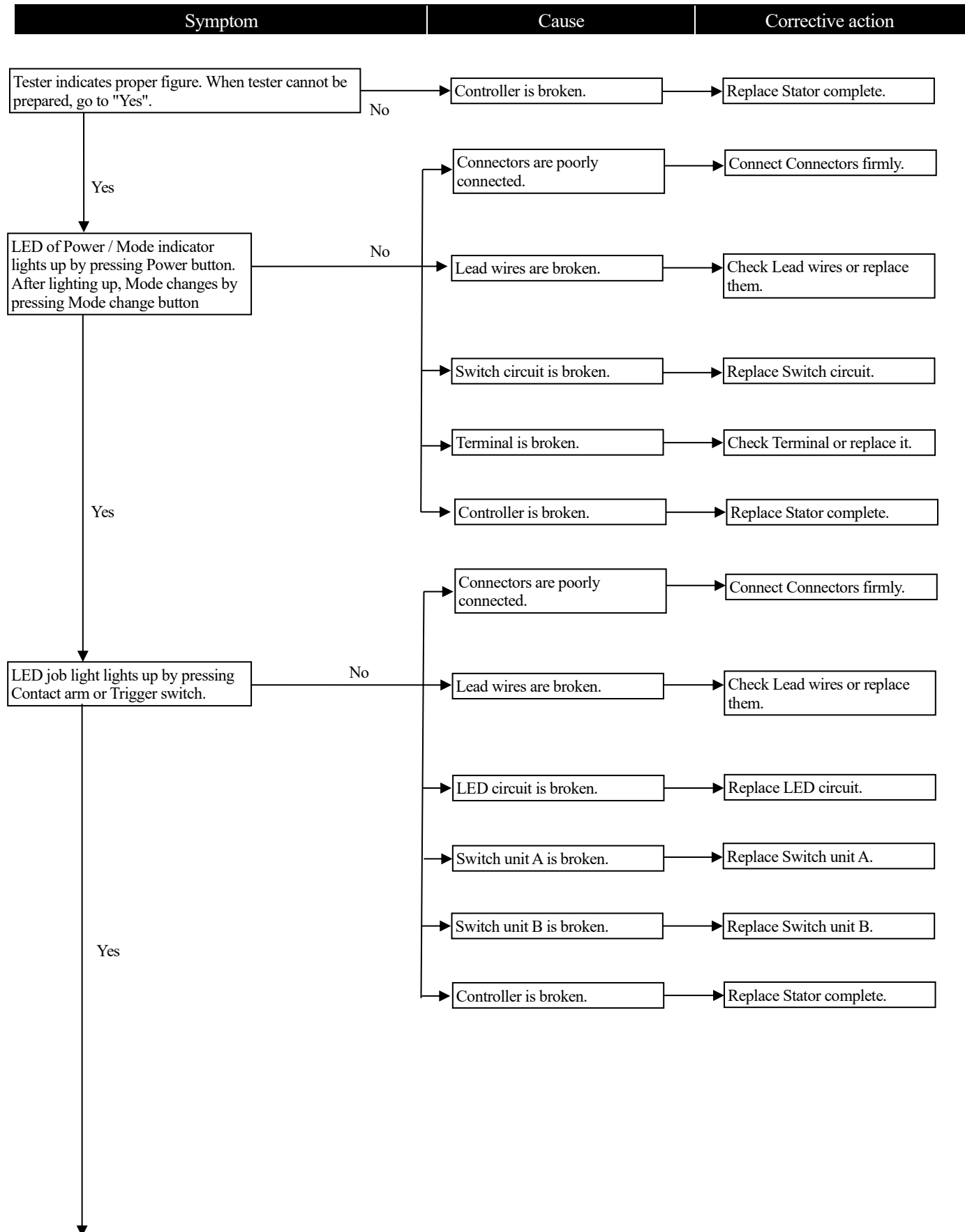

(Continued to the next page)

(Continued from the previous page)

